



# **INSTALLATION & USER'S GUIDE**

RadiusX

Indian FTR 1200, FTR Rally, & FTR 1200 S

# **TABLE OF CONTENTS**

OVERVIEW .....	3
INSTALLATION TIPS .....	3
TOOLS NEEDED.....	4
INCLUDED PARTS .....	5
DISASSEMBLE THE CLUTCH .....	6
CLUTCH PACK INSTALLATION.....	10
Notes for installation.....	10
Clutch pack.....	10
PRESSURE PLATE INSTALLATION.....	13
PRIMARY COVER INSTALLATION.....	15
SET THE INSTALLED GAP .....	18
CHECK FREE PLAY GAIN.....	19
Learn how to check Free Play Gain .....	19
Two Ways to Check for Free Play Gain .....	21
The Rubber Band Method .....	21
The Hand Method .....	24
Adjust the Installed Gap.....	25
BREAK IN THE NEW CLUTCH.....	26
EXP TUNING OPTIONS.....	28
Changing the EXP springs .....	29
SHIFTING AND OPERATION .....	30
MAINTENANCE.....	32
Disk inspection examples.....	32
TROUBLESHOOTING.....	34
NEED ADDITIONAL HELP?.....	35

# OVERVIEW

This kit replaces the OE (Original Equipment) or “stock” clutch pack with a Rekluse-designed high quality clutch pack designed specifically for your bike model. The following is a summary of what is replaced:

- All OE steel drive plates will be replaced with Rekluse drive plates
- All OE friction disks will be replaced with Rekluse TorqDrive® friction disks and EXP disk
- The OE pressure plate springs will be replaced.

# INSTALLATION TIPS

- Read the safety information sheet included with your kit.
- If you install this product for a customer or another person, instruct them to read the **Safety Information** document and the **Installation and User Guide** before operating the bike with the product.
- Protect eyes and skin – wear safety glasses and thin disposable work gloves. Work in a well ventilated area.
- Read this entire document before performing any steps.
- Use clean, quality oil that meets JASO-MA or JASO-MA2 engine oil standards for best performance.
- Rekluse offers Factory Formulated Oil™ developed specifically for Rekluse products. Rekluse Factory Formulated Oil is a perfect complement to any OEM or aftermarket wet clutch. Visit [www.rekluse.com](http://www.rekluse.com) to learn more.
- Use the torque values listed in the instructions. Otherwise, use the torque specifications found in your OE service manual.

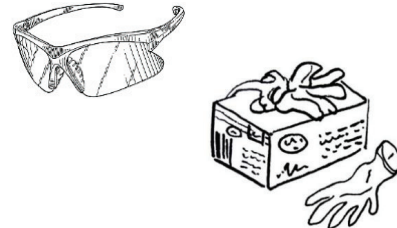

## **TOOLS NEEDED**

- 4mm allen wrench
- 5mm allen wrench
- 6mm allen wrench
- 8mm socket
- 10mm socket
- 12mm socket
- 12mm wrench
- Torque wrench in-lb
- Torque wrench ft-lb
- Picks
- Fluid catch container

# INCLUDED PARTS

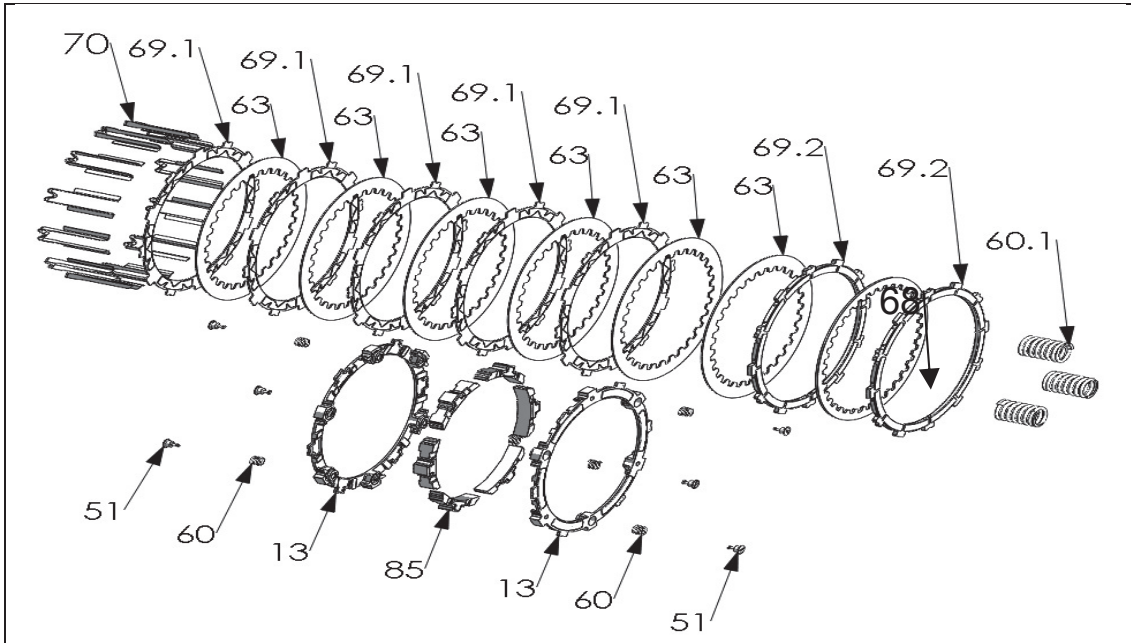

Item	Description	Qty.
13	EXP 3.0 BASE - HD Big Twin	2
51	Fasteners - 1/4-Turn Pin	6
60	EXP Adjustment Springs	6
60.1	Pressure Plate Springs	3
63	Drive Plate - 0.040in BT CVO	6
68	Drive Plate - 0.065in BT CVO Top	1
69.1	TorqDrive Friction Disk - Thin	5
69.2	Friction Disk - LC8 / CVO - Thick .150in 3.81mm	2
70	Basket Sleeves	12
85	EXP Wedges	6
Not Shown	Velcro straps	2
Not Shown	Orange Free Play Gain rubber band	1
Not Shown	Clutch lever warning label	1

Visit [www.rekluse.com/support](http://www.rekluse.com/support) for a full parts fiche illustration and part numbers.

# DISASSEMBLE THE CLUTCH

1. Stand the bike up on a suitable bike stand or lift.



2. Drain the engine oil into a suitable container by removing the two oil drain plugs.

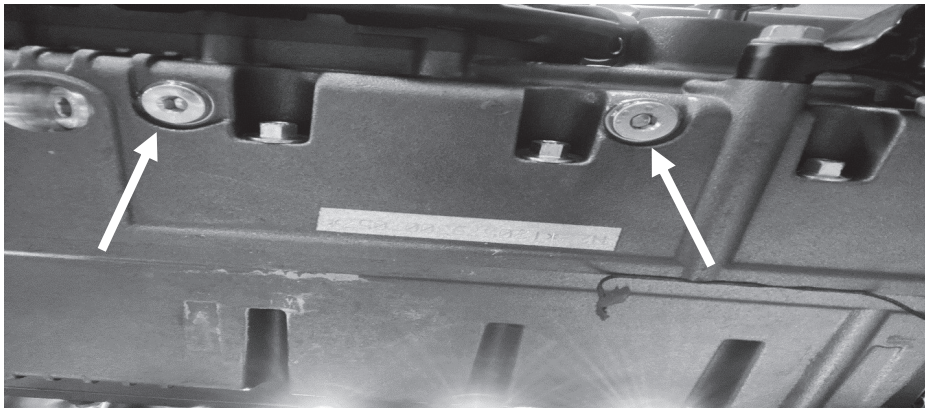

3. Remove the center exhaust heat shield.

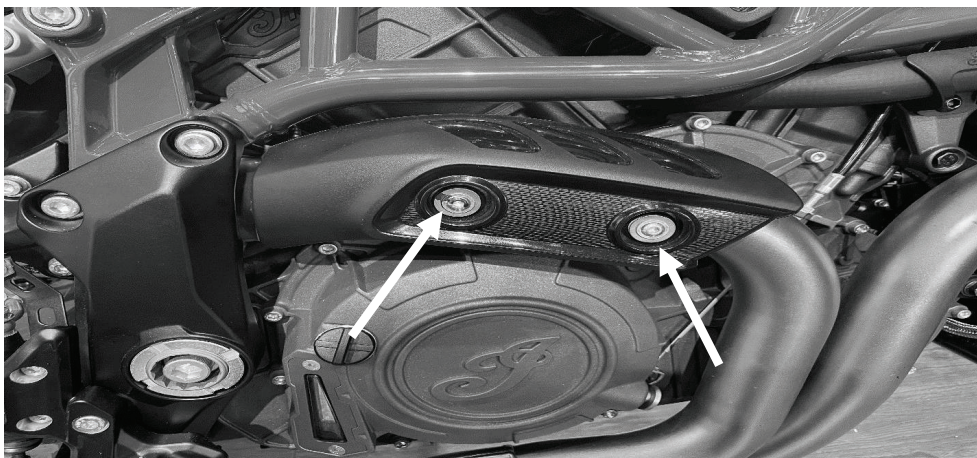

4. Remove the front exhaust heat shield.

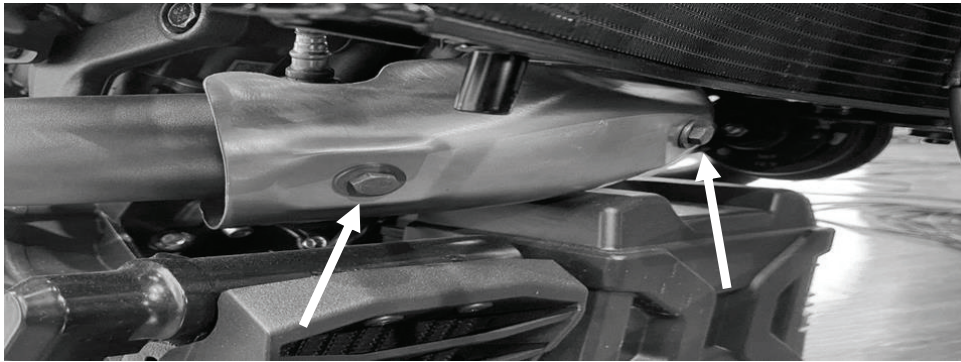

5. Unplug the oxygen sensor connector from the front header pipe.

6. Remove the head pipe fasteners securing the head pipe to the cylinder head.

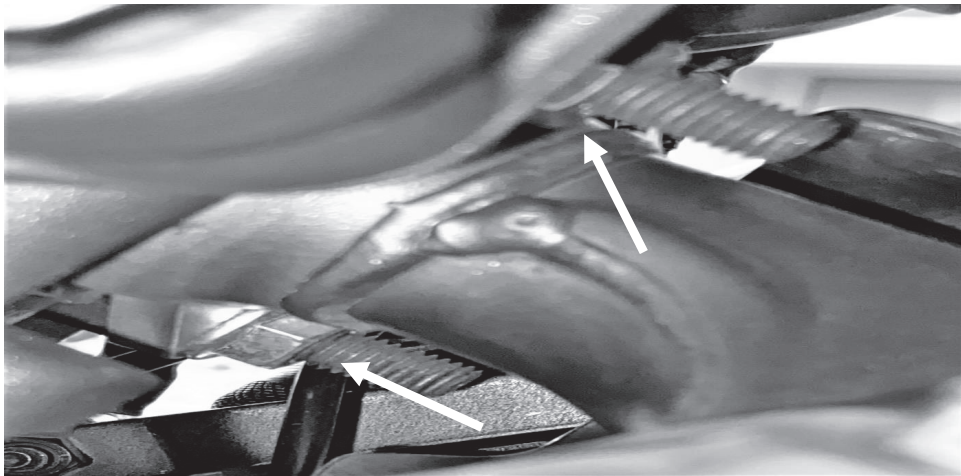

7. Loosen the two exhaust clamps securing the front and rear header pipes.

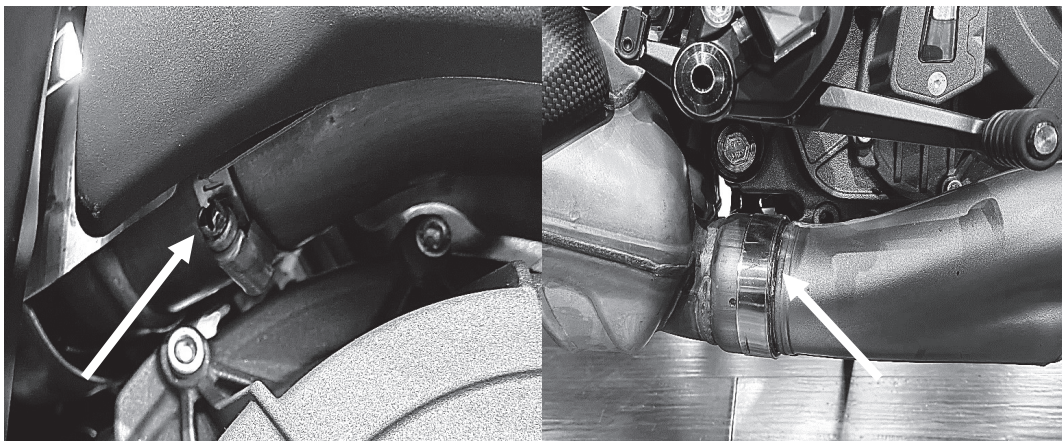

8. Remove the front head pipe assembly.

9. Remove the jam nut from the clutch cable housing and pull the housing out from the engine case.

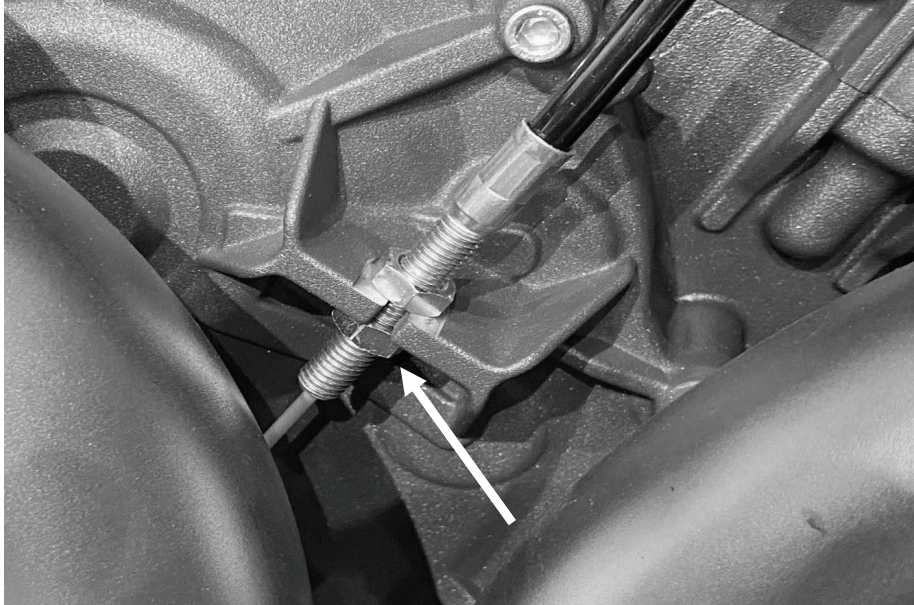

10. Remove the clutch cable from the actuator arm.



11. Remove the primary cover bolts.
12. Remove the primary cover.

13. Remove the following clutch components: pressure plate bolts, spring ring, springs, pressure plate, clutch pack, judder spring, and judder spring seat.

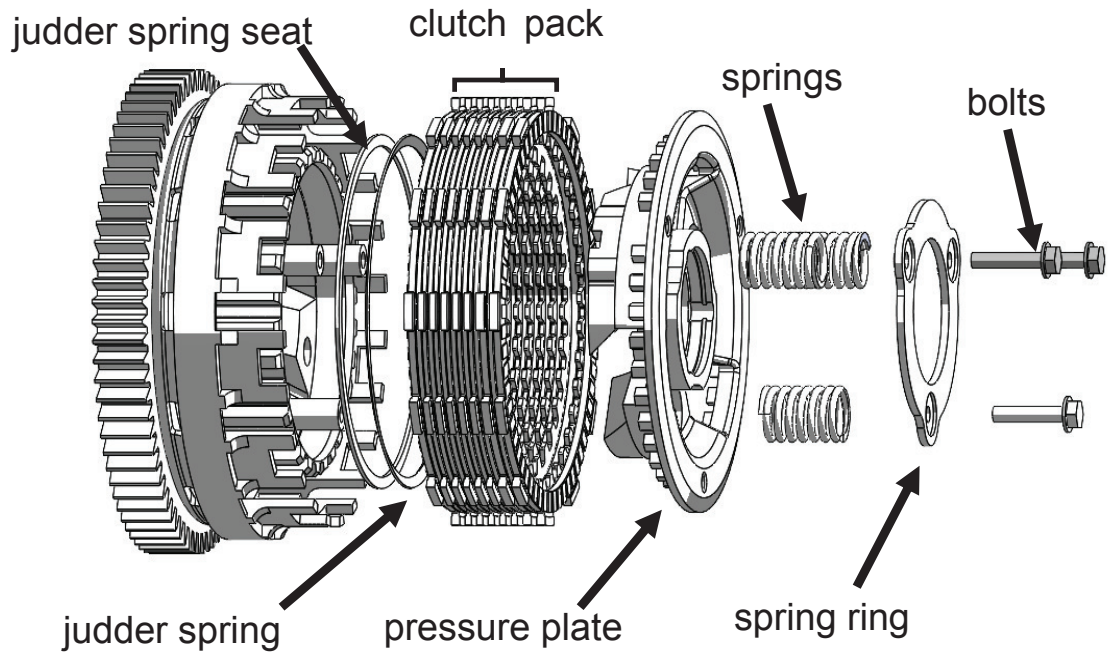

# CLUTCH PACK INSTALLATION

## Notes for installation

- Some friction disks are marked with a small colored dot. This mark is used for processing and can be ignored.
- See the **Setup Sheet** located at the back of the manual for the proper clutch pack configuration.
- The OE basket has “half slots” at the top of the basket tangs. This Rekluse product requires the entire clutch pack be installed into the MAIN (deeper) basket slots. Installing the clutch pack into the “half slots” will cause performance issues. See the following picture for reference.

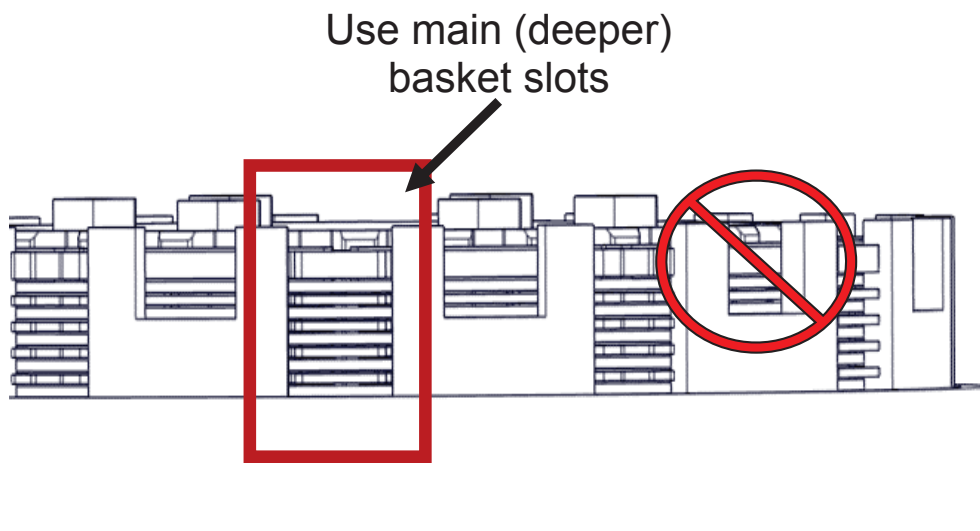

## Clutch pack

1. Soak the EXP disk and all friction disks in engine oil for 5 minutes. Make sure the EXP and friction disks are coated on both sides.

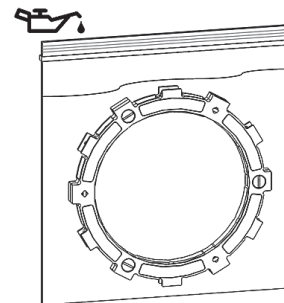

2. Inspect the clutch basket for notching. Do not install sleeves or use product with a notched basket. Notched basket tang faces can cause the sleeves to break. Do not use baskets that have been filed, machined, or modified on the tangs. Replace basket if necessary.

**⚠ WARNING**

**Failure to inspect the basket and replace if necessary could result in death, serious injury, and/or property damage.**

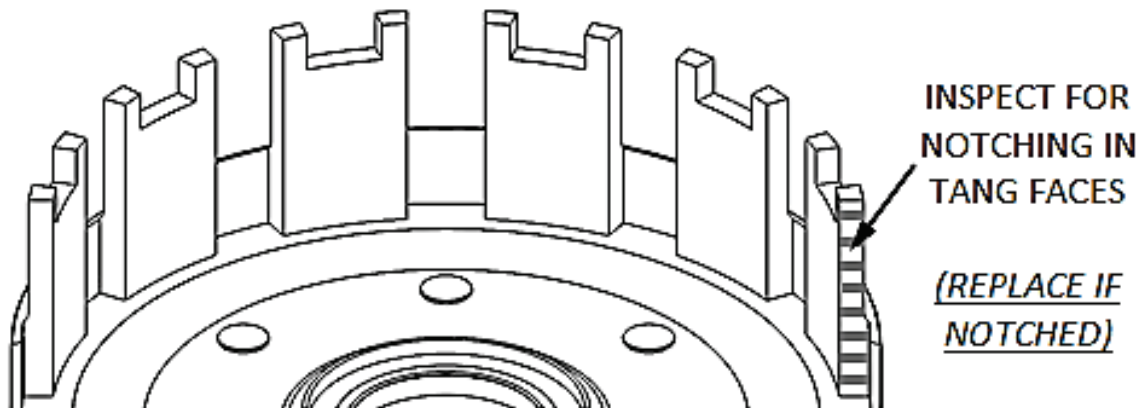

3. Install **ALL** the Rekluse basket sleeves into the basket slots. Make sure the sleeve tabs sit against the inside of the basket, then push the sleeves down until they contact the bottom of the tang slot. See pictures for reference.

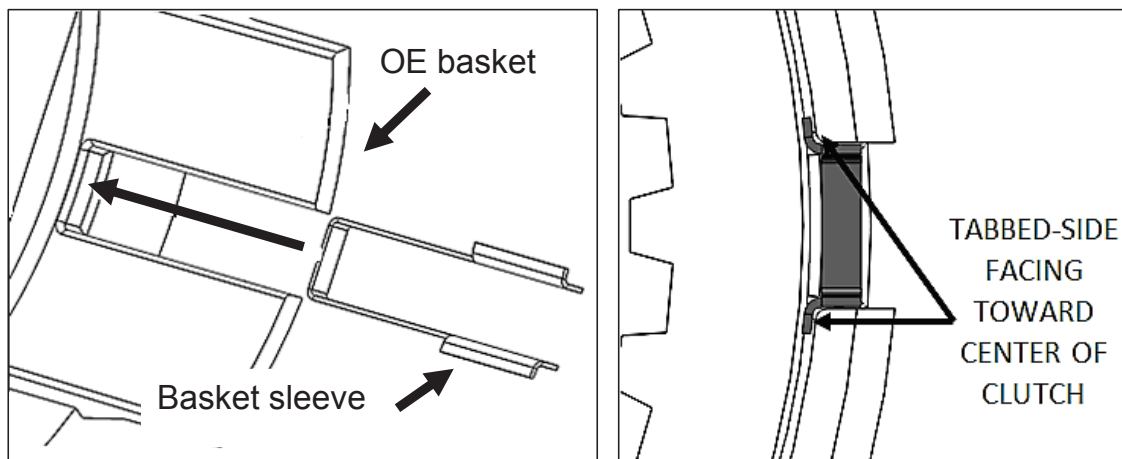

4. Install a TorqDrive friction disk followed by a 0.40" drive plate.
5. Continue to alternate the remaining 4 TorqDrive friction disks with 4 of the 0.040" steel drive plates.
6. On top of the last drive plate, install the EXP assembly.
7. Install the last 0.040" drive plate

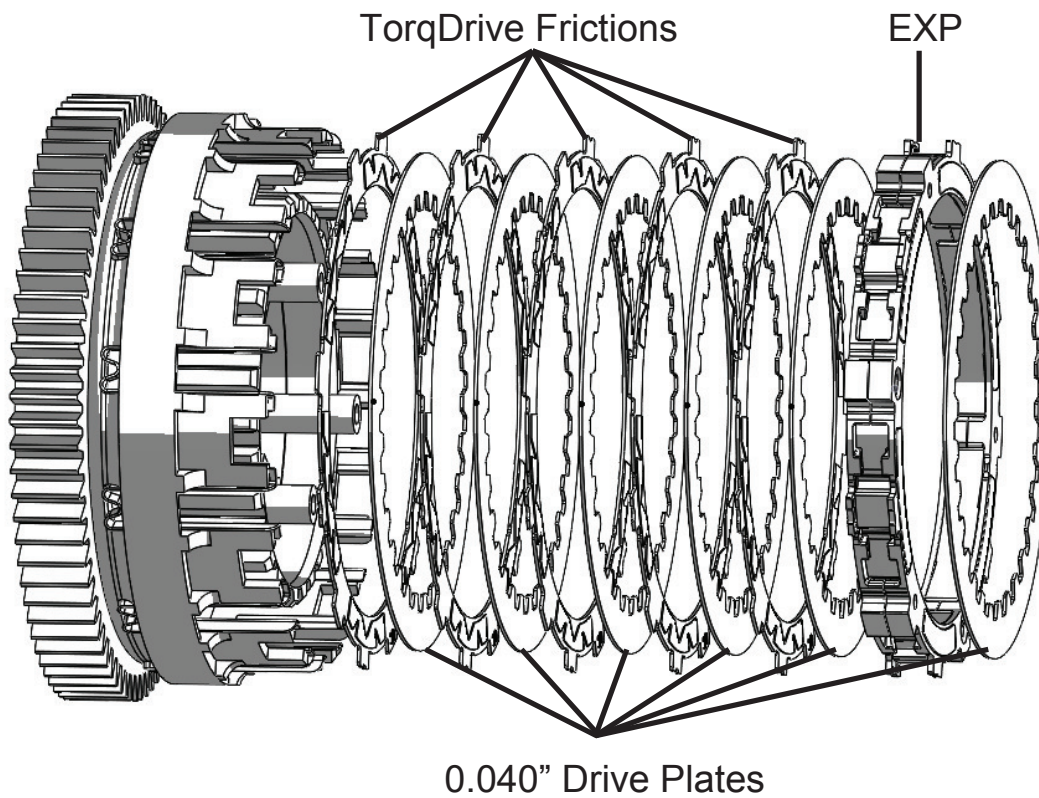

# **PRESSURE PLATE INSTALLATION**

1. Turn the pressure plate over onto a work bench. Place one .150" thick friction disk on to the pressure plate.
2. Next place the .065" drive plate on to the pressure plate and place the last .150" thick friction disk.

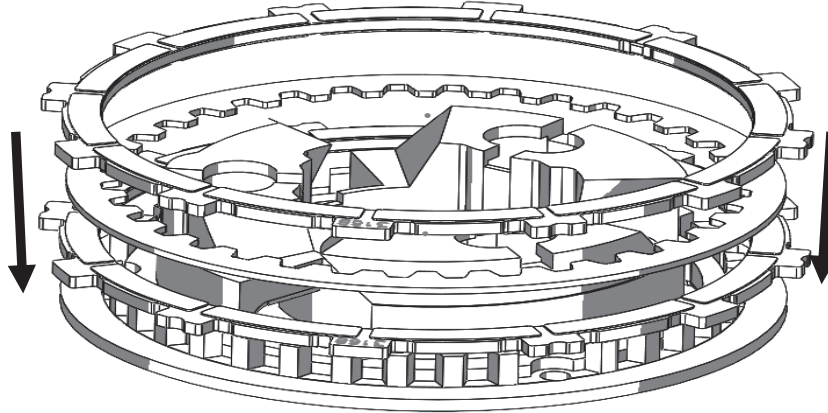

3. To install the pressure plate, hold onto the friction tabs and pressure plate, align the pressure plate with the center hub and the friction tabs with the basket tangs.

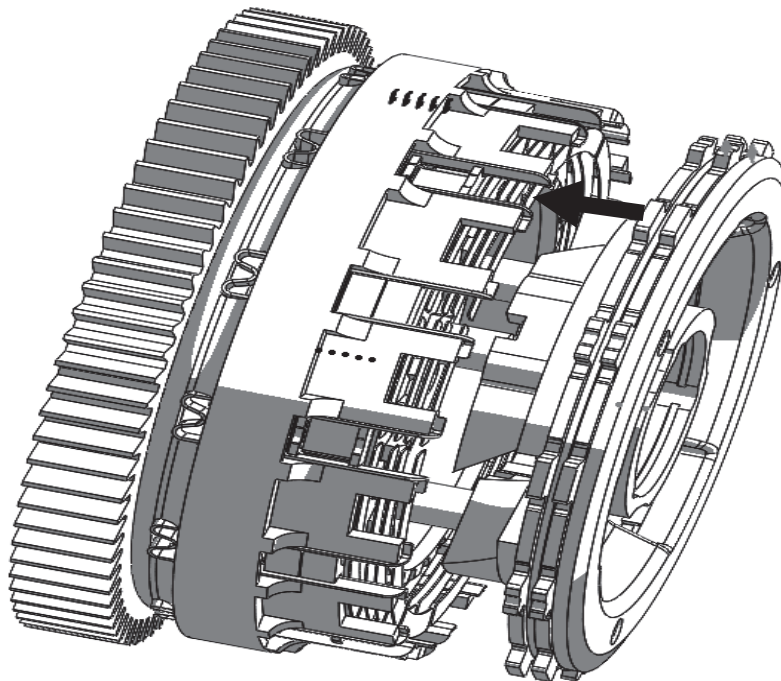

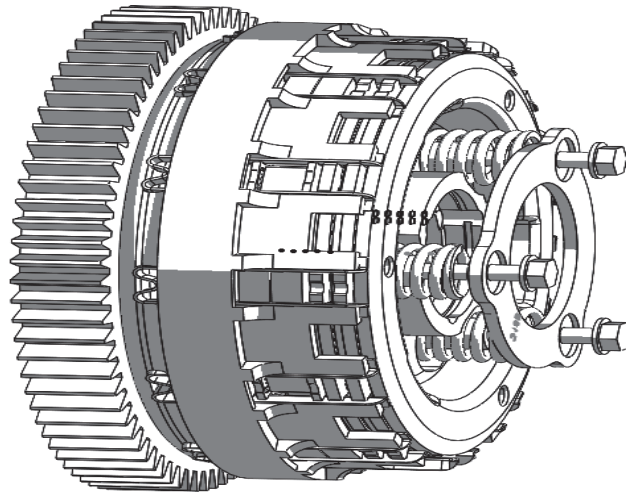

4. Install the Rekluse pressure plate springs, followed by the OE spring ring and bolts.
5. Evenly tighten the bolts, then torque the bolts to **80 in-lb (9 N-m)**.

# **PRIMARY COVER INSTALLATION**

1. Clean the gasket surface of the crankcase and primary cover.

**NOTE:** If the primary gasket was damaged during disassembly it will be necessary to replace the gasket. (Indian part # 5416661 GASKET, PRIMARY COVER AP)

2. When reinstalling the primary cover, make sure that the clutch rack is angled so the clutch shaft will align and slowly place the cover onto the engine case.
3. Check the position of the actuator arm. The actuator arm should be positioned like the actuator arm in the image below. If the arm is not in this position, remove the cover, make the necessary adjustments and repeat step 2.

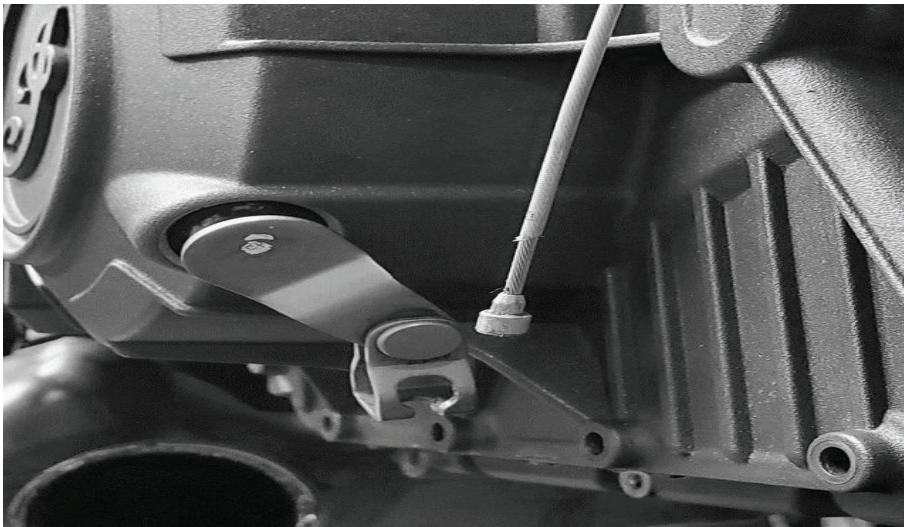

**NOTE:** The actuator arm will not be in the same position as it was with the OE clutch, this will be adjusted when setting the installed gap

4. Tighten the bolts using the pattern indicated in the picture below in small increments before torquing the cover bolts to **106 in-lb (12 Nm)**.

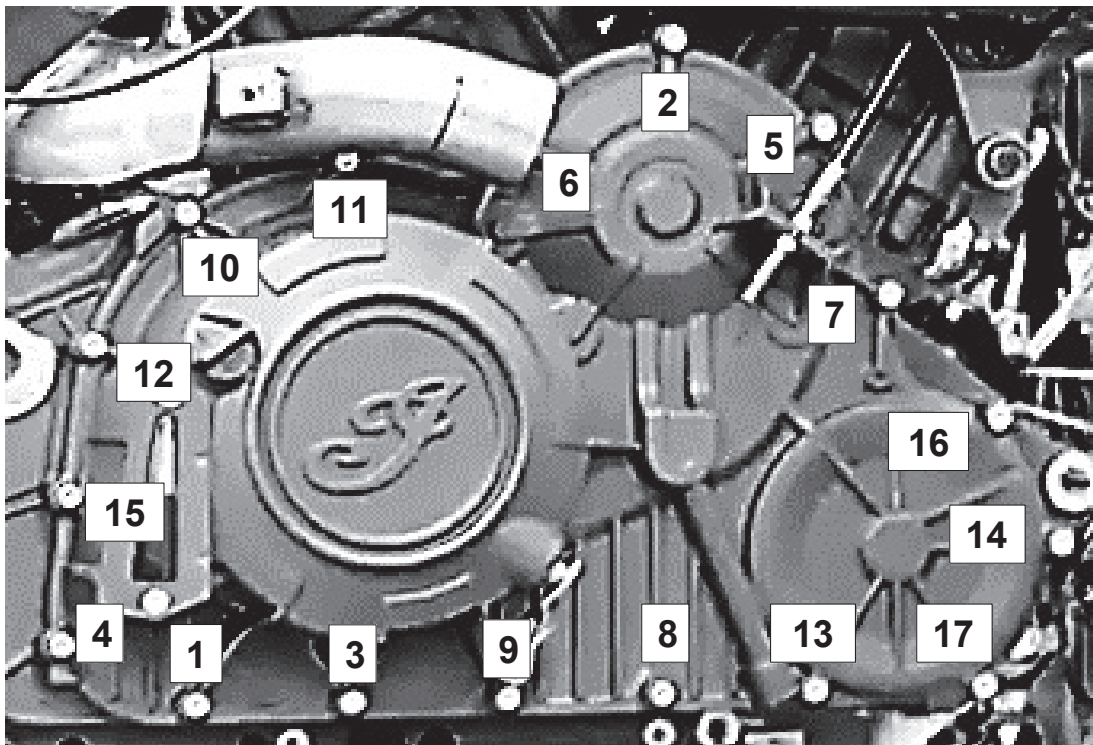

5. Reattach the clutch cable to the actuator arm.
6. Reinstall the clutch cable to the engine case, but do not adjust the cable, cable adjustment will occur when setting Free Play Gain.
7. Reinstall both oil drain plugs, torque to **15 ft-lbs (20 Nm)** and fill with oil to factory specifications (*oil and filter change approximately 4 US quarts*).

**NOTE:** Make sure to reinstall the sealing washers to the drain plug bolts before reinstalling the bolts

8. Install the head pipe assembly.
9. Install the head pipe fasteners and torque to **16 ft-lbs (22-Nm)**.
10. Position the two exhaust clamps and torque to **144 in-lbs (16 Nm)**.
11. Plug in the oxygen sensor connector from the front header pipe.

12. Install the front exhaust heat shield and torque the fasteners to **88 in-lbs (10 Nm)**.
13. Install the center exhaust heat shield and torque the fasteners to **88 in-lbs (10 Nm)**.

## **SET THE INSTALLED GAP**

The “installed gap” is the separation in the clutch pack created by the tension adjusted into the clutch cable. This gap is what allows the clutch to spin freely until the desired RPM is reached for engagement. The installed gap must be set correctly.

1. At the clutch perch set the adjuster to the mid-point.
2. Next, at the cable adjuster, turn the top nut clockwise until there is no free play in the lever.
3. Once there is no free play in the lever turn the top nut clockwise an additional 6 complete turns to lift the pressure plate. **This is your starting point and not the final adjustment.**

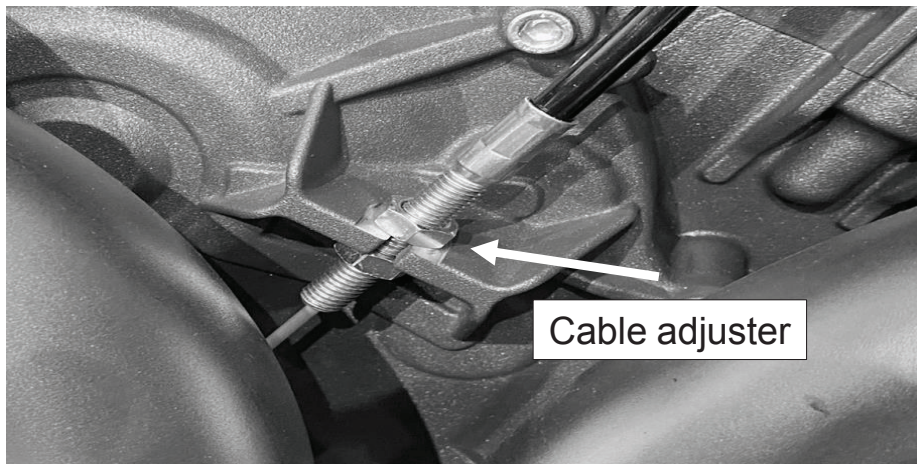

4. Check Free Play Gain (next section) to adjust the cable tension to its final setting. If there is not enough Free Play Gain, turn the cable adjuster counterclockwise until Free Play Gain is within specification. Turn the cable adjuster clockwise if there is too much Free Play Gain until the Free Play Gain is within specification.

**NOTE:** Free Play Gain specification is between 1/8”-1/4” (3mm-6mm) lever movement

5. Once proper Free Play Gain is achieved, tighten the jam nut.

## **CHECK FREE PLAY GAIN**

It is very important that you understand how to verify the correct installed gap by checking Free Play Gain. The installed gap is what allows the auto function of the product to perform properly.

### **Correct Free Play Gain = Correct installed gap**

Setup, break-in, and rechecking the installed gap is CRUCIAL. Failure to properly maintain your installed gap can result in premature wear or failure of your clutch. Use the following steps to verify the installed gap by checking Free Play Gain.

#### **⚠ WARNING**

**Failure to check and verify Free Play Gain can cause failure or damage to this product. Setting the correct installed gap is critical for clutch performance.**

## **Learn how to check Free Play Gain**

If you are familiar with checking Free Play Gain, check for Free Play Gain then skip to the “Adjust the Installed Gap” section.

If Free Play Gain is new to you, follow the instructions below to help you learn this important step. You can also view the video entitled “How to Check Free Play Gain” on our website at <https://rekluse.com/support/videos>.

Checking Free Play Gain allows you to externally monitor the installed gap so you can know when to make an adjustment if the installed gap is too large or too small.

The correct installed gap is verified by observing and feeling the increased free play movement in the clutch lever. This extra movement is called “Free Play Gain.”

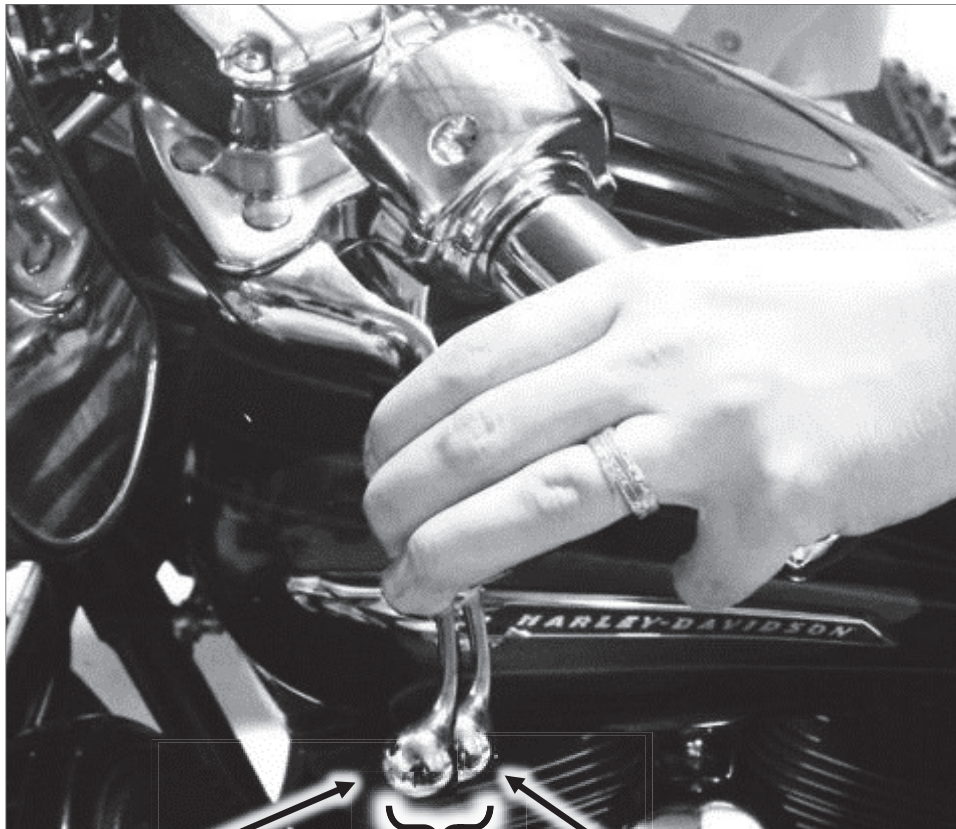

Lever with "slack" removed

Lever position around 2,000 RPM

**Free Play Gain**  
1/8"-1/4" (3 mm-6 mm) lever movement

- **If there is too much Free Play Gain**, the installed gap is too small.
  - The vehicle may drag and stall because it has difficulty disengaging the clutch. It may also be difficult to shift.
  - Too much Free Play Gain will not hurt the clutch, but it will negatively affect clutch performance. dd
- **With too little or no Free Play Gain**, the installed gap is too large.

- This means when the EXP is fully expanded it does not lift the pressure plate. The clutch may slip and make the vehicle seem like it is losing power.
- The vehicle may not move forward even though the engine RPM increases as if the clutch lever is slightly pulled.
- Too little Free Play Gain will cause the clutch system to burn up.

**Optimal Free Play Gain yields 1/8”-1/4” (3 mm-6 mm) of clutch lever movement**, measured at the ball end of the lever. This measurement at the lever correlates to achieving the ideal installed gap.

## **Two Ways to Check for Free Play Gain**

The following steps explain **2 ways** to check Free Play Gain. One way uses the rubber band Rekluse includes in the clutch kit, and one uses your hand. You can use either method to check for Free Play Gain.

Rekluse recommends that you begin with the rubber band method first to check for Free Play Gain and then learn the hand method. The rubber band will help you learn how to recognize Free Play Gain until you are comfortable with the hand method. Learning to check Free Play Gain by hand effectively and comfortably can make it easy to check Free Play Gain every time you ride.

## **The Rubber Band Method**

Use the rubber band method for the initial set up. It can also be used before each ride until you feel comfortable checking the Free Play Gain using the hand method.

### **⚠ WARNING**

**BEFORE YOU BEGIN, verify that the vehicle is in NEUTRAL before checking Free Play Gain. Failure to do so may result in the vehicle lurching forward, and loss of control and/or injury may result.**

**A Rekluse auto-clutch can make your motorcycle appear to be in neutral when in gear, even when the engine is running and clutch lever released.**

**Motorcycles equipped with a Rekluse auto-clutch can move suddenly and unexpectedly and cause riders to lose control. To avoid death, serious injury, and/or property damage, always sit on the motorcycle to start it.**

a) Before you begin, place the vehicle in **NEUTRAL**, start the engine and let it warm up for 2-3 minutes to idle down and warm the engine oil.



b) Stretch the included rubber band between your thumbs, then place the top end of the rubber band on the outer end of the left handlebar grip.



c) While holding the top end of the rubber band against the handlebar, stretch the band downward, then loop it through itself.

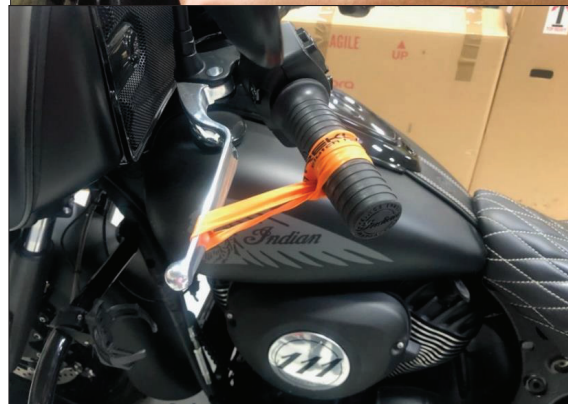

d) Pull the band through the loop, then attach it to the outside end of the clutch lever. This will take up the initial free play (slack) and put the lever in a position to detect the Free Play Gain.

- e) While still in **NEUTRAL**, quickly rev the engine between 2,000-2,500 RPM (1/4 to 1/2 throttle), then let it return to idle. Notice the movement in the clutch lever when the engine is revved. This is your Free Play Gain.

**Note:** *It is very important the motor returns to idle before revving the engine again or Free Play Gain will not be correct.*

- f) When the vehicle returns to idle, rest your hand across the clutch lever. Rev the engine again to 2,000-2,500 RPM so you can observe the movement while feeling for Free Play Gain with your hand.

# The Hand Method

Use the hand method to check Free Play Gain before the start of every ride for optimum performance and longevity of your new clutch.

- a) Before you begin, place the vehicle in **NEUTRAL**, start the engine and let it warm up for 2-3 minutes to idle down and warm up the engine oil.
- b) With the vehicle at idle, apply enough pressure to the clutch lever to take up the initial free play (slack) in the clutch lever.
- c) While still in **NEUTRAL**, continue to apply light pressure and quickly rev the engine between 2,000-2,500 RPM (1/4 to 1/2 throttle), then let it return to idle. Notice the movement in the clutch lever when the engine is revved. This is your Free Play Gain.
- d) When the vehicle returns to idle, rev the engine between 2,000-2,500 RPM a second time to verify the Free Play Gain again.

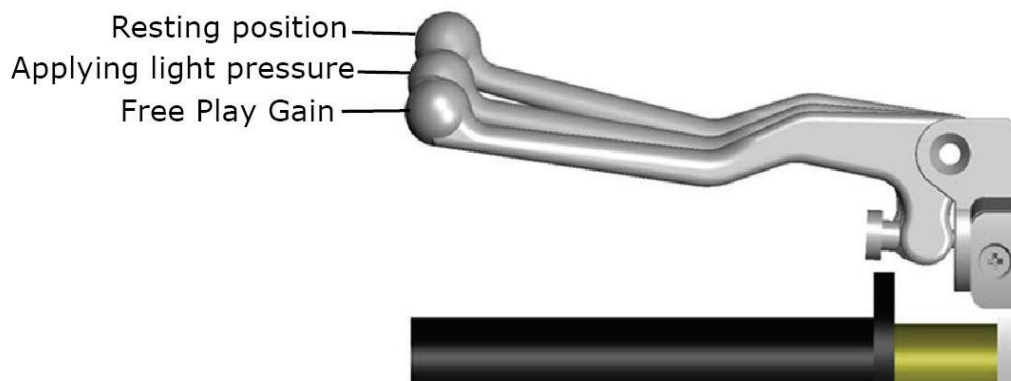

## **Adjust the Installed Gap**

After checking for Free Play Gain, you may need to adjust the installed gap. If Free Play Gain is optimal, continue to “SHIFTING AND OPERATION”

If Free Play Gain is not optimal, the installed gap needs to be adjusted.

The installed gap should be fine-tuned in small increments and then recheck Free Play Gain. Refer to the table below to set the proper installed gap based on your Free Play Gain.

Symptom	Reason	Solution
<ul style="list-style-type: none"><li>• Too much Free Play Gain: Clutch lever moves in too far</li><li>• Clutch has excessive drag or stalls</li><li>• It is difficult to fully override the clutch with the lever</li></ul>	Installed gap is too small	<p>Tighten the cable; increase the length of the in-line cable adjuster housing and/or the lever perch adjuster (extend the adjusters) until the correct amount of Free Play Gain is achieved.</p> <p>Recheck Free Play Gain.</p>

<ul style="list-style-type: none"> <li>• Too little Free Play Gain: Clutch lever only moves slightly or does not move at all</li> <li>• Clutch slips</li> <li>• Vehicle seems to lose power</li> </ul>	<p>Installed gap is too large</p>	<p>Reduce the length of the cable housing (collapse the adjusters) until the correct amount of freeplay gain is achieved.</p> <p>Recheck Free Play Gain.</p>
--	-----------------------------------	--

## **BREAK IN THE NEW CLUTCH**

Once you install your new clutch, it is important to break it in. A series of roll-on starts are used to break in the clutch. Follow these procedures for breaking in your clutch and any time new friction disks, EXP bases, Teflon pads, or wedges are installed.

### **⚠ WARNING**

**Failure to follow the break-in procedure and oil screen inspection process could cause motor oil delivery failure, which can result in motor failure, serious injury, or death.**

<b>Break-in Procedure</b>	<b>Number of times</b>
<p>1. Warm up the vehicle for 2-3 minutes. With the vehicle in <b>NEUTRAL</b> and your hand <b>off</b> of the clutch lever, rev the engine 10 times, being sure to let it <b>return to idle</b> between each rev cycle.</p>	<p>① ② ③ ④ ⑤</p> <p>① <b>N</b> ② ③ ④ ⑤</p>

<p>2. With the engine still running, pull in the clutch lever, then shift the vehicle into 1<sup>st</sup> gear. Slowly release the clutch lever. The vehicle should stay running and in place or have a slight amount of forward creep.</p> <p>3. With the vehicle idling in first gear, slowly apply throttle to begin moving.</p> <p>4. Without using the clutch lever, accelerate moderately to approximately 2,500 RPM to fully lock up the clutch and come to a complete stop. Repeat 15 times.</p>	 <p>15 roll-on starts</p>
--	---

**Note:** *If the engine wants to stall or the creep is excessive, the idle may be too high or the installed gap may be too small. Make necessary adjustments before proceeding.*

<p>5. Place the vehicle in <b>NEUTRAL</b> and recheck Free Play Gain. Continue to adjust the installed gap until the clutch lever is 1/8"-1/4" (3 mm-6 mm).</p>	 <p>Recheck Free Play Gain and adjust the installed gap</p>
---	---

**Note:** *Your clutch pack will expand with heat, so final adjustment to Free Play Gain should be made when the vehicle is warm. Remember not to ride without sufficient Free Play Gain.*

 **CAUTION**

***Do not perform 2<sup>nd</sup> and 3<sup>rd</sup> gear starts with this product. Always keep the motorcycle in first gear when taking off from a stop. Taking off from a higher gear can cause premature clutch wear and damage the product.***

***DO NOT DYNO TEST YOUR MOTORCYCLE BEFORE BREAK IN! Always break in the product before performing dyno testing. Read the included dynamometer sheet for more information.***

## **EXP TUNING OPTIONS**

You can tune the engagement RPM of the EXP disk by changing the spring configuration. The EXP disk comes set with the recommended “**Medium**” setting from Rekluse. **For other EXP tuning options, see the Setup sheet at the back of the Installation Manual.**

To prevent freewheeling and maximize engine braking, set the EXP so there is a slight amount of drag while the vehicle is idling in gear and warmed up.

With correct Free Play Gain and the vehicle in gear, the vehicle should move forward under slight opening of the throttle.

## Changing the EXP springs

Use the following steps to change the EXP spring configuration. It is **NOT necessary** to disassemble the EXP halves to change springs!

1. Using a flat-blade screwdriver, push the  $\frac{1}{4}$  turn pin in far enough to clear the opposite side of the EXP to unlock the pin.
2. With the pin still pushed past the base, turn  $90^\circ$  to remove the pin and spring.

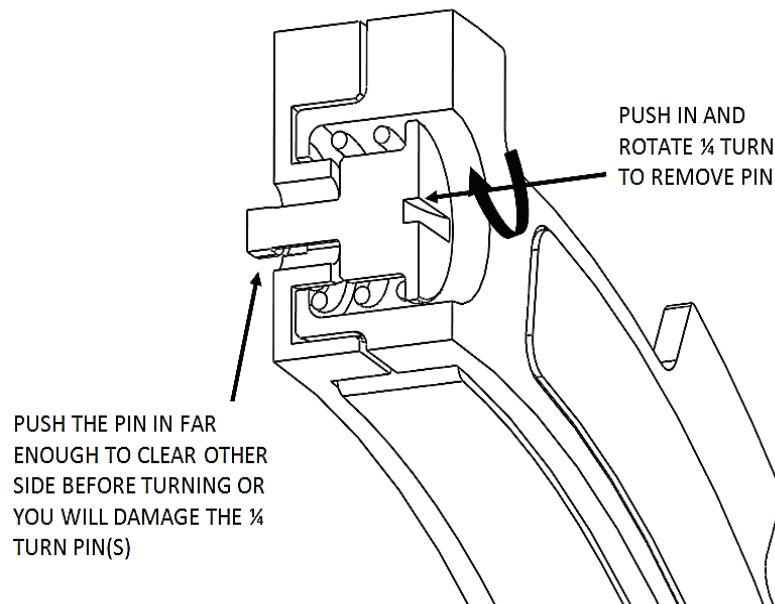

3. Remove the remaining 2 pins and springs from the EXP base.

4. Drop new springs into the spring pockets, then add the  $\frac{1}{4}$  turn pins.

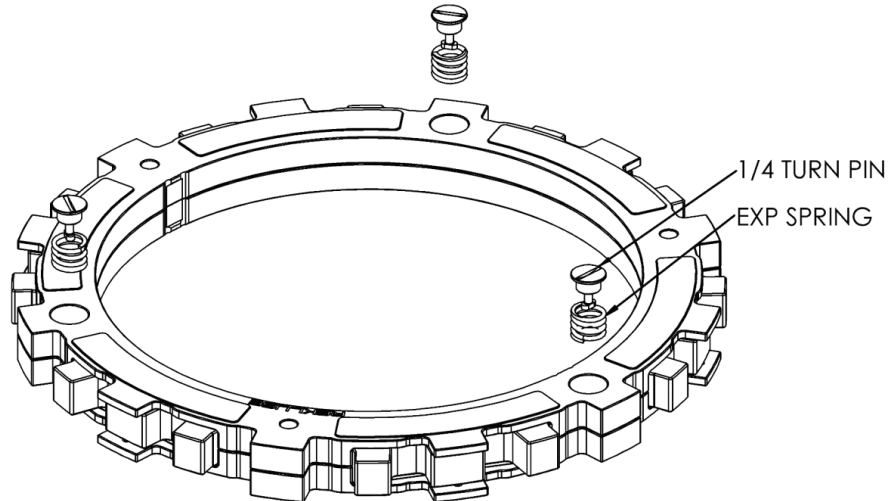

5. To lock, push the  $\frac{1}{4}$  turn pin in far enough to clear the base, then turn  $90^\circ$  and release the pin. The pins should sit almost flush with the EXP base.
6. Flip the EXP friction disk over and repeat on the other side depending on engagement preference.
7. If you need to disassemble the EXP disk, you can watch the video on our website under Tech Tips at [www.rekluse.com/support/videos](http://www.rekluse.com/support/videos).

## **SHIFTING AND OPERATION**

- Always use proper gear selection for the speed and situation whether accelerating or slowing down.
- When accelerating from a stop it is best to start in 1st gear to prevent excessive slipping of the clutch. Starting in too tall a gear repeatedly will prematurely wear out the clutch resulting in failure.



# **MAINTENANCE**

To keep your clutch performing at its best, perform regular maintenance on your clutch.

- Keep up with regular oil changes according to the manufacturer's recommendations. Clutch performance and longevity depend on oil quality. Tired, dirty, or worn oil may cause excessive clutch drag or noise.
- Use oil recommended by the manufacture of your vehicle.
- Inspect all of your clutch parts for signs of wear or excessive heat, and replace components as necessary. This includes your basket sleeves. Clutch wear is dependent on the riders use.
- Measuring the friction disks for wear. This can help determine if the components need replacing.
  - Rekluse thin friction disk minimum allowable thickness = **0.068" (1.7 mm)**
- Replace friction disks if they measure below specifications or if the disks are glazed and/or burnt.
- Repeat the break-in procedure anytime you replace the frictions disks. Always soak friction disks in oil for at least 5 minutes before installing.
- Replace the drive plates if they show signs of excessive heat.

## **Disk inspection examples**

When inspecting the clutch pack, the following pictures can be used as a reference. **These are best viewed in color by viewing this install document on [www.rekluse.com/support](http://www.rekluse.com/support).**

**Drive Plates** – If the clutch pack is getting high amounts of heat, purple, blue, or black color can be seen on the drive plate teeth. See pictures below. Not all drive plates look the same and may look different than pictured.



Normal Heat

High Heat  
(Blue)

Excessive Heat  
(Black)

**Friction Disks** – Due to the dark color of the friction material, the friction disks will appear almost black as soon as they are put in oil. During inspection, look for glazing of the friction material. Glazing will appear shiny and feel like glass, even after oil is cleaned from the friction disk. Not all friction disks look the same and may look different than pictured.



Normal Friction



Glazed Friction

# **TROUBLESHOOTING**

## **Clutch Drag:**

- *Cold Drag Only* – Cold drag is normal. The clutch will usually have some amount of drag before the oil warms to operating temperature. Be sure to warm up the vehicle before riding.
- *Hot and Cold Drag* – Change oil. Check for warped or non-flat drive plates in the clutch pack.

## **Clutch Slip:**

If clutch slip occurs, inspect the clutch for signs of wear or heat.

# **NEED ADDITIONAL HELP?**

## **Website**

[www.rekluse.com/support](http://www.rekluse.com/support)

## **Frequently Asked Questions**

[www.rekluse.com/faq](http://www.rekluse.com/faq)

## **Support Videos**

[www.rekluse.com/support/videos](http://www.rekluse.com/support/videos)

## **Phone**

(208) 426-0659

## **Technical Support**

Contact Technical Support for questions related to product installation, tuning, and performance.

Technical Support hours:

Monday thru Friday: 8:00 a.m. - 5:00 p.m.

Mountain Time zone

Email: [tech@rekluse.com](mailto:tech@rekluse.com)

## **Customer Service**

Contact Customer Service for additional product information, orders, and returns.

Customer Service hours:

Monday thru Friday: 8:00 a.m. - 5:00 p.m.

Mountain Time zone

Email: [customerservice@rekluse.com](mailto:customerservice@rekluse.com)

