

1 The Eastgate Office Centre
Eastgate Road
Bristol BS5 6XX
United Kingdom



Switchboard: +44 (0)117 951 5151
Main Fax: +44 (0)117 952 4103
E-mail: general@vca.gov.uk
Web Site: www.vca.gov.uk

VEHICLE CERTIFICATION AGENCY

THE UNITED KINGDOM VEHICLE APPROVAL AUTHORITY

Rev 1/93



COMMUNICATION CONCERNING APPROVAL GRANTED OF A TYPE OF
REAR-VIEW MIRROR PURSUANT TO REGULATION NO 81 (STU)

Approval No: 001094

1. Trade name or mark of the equipment:
Trade name: FU

Trade mark: 

2. Equipment type: FP-318

3. Brief description including in particular the following information:

3.1 Main dimensions of the reflecting surface: Height=80.20 mm; Width=133.62mm

3.2 Nominal radius of curvature of the reflecting surface: R1250+150

4. Manufacturer's name and address:

Fu-Hwa Mirror Company Limited
688, Chang-Lu Road, Sec. 7
Lukang
Chang-Hwa Hsien
Taiwan
Republic of China

5. If applicable, name and address of manufacturer's representative: Not applicable

6. Equipment submitted for approval on: 20 June 2005

7. Technical service responsible for conducting approval tests: Vehicle Certification Agency

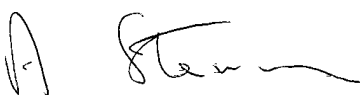

8. Date of report issued by that service: 21 June 2005
9. Number of report issued by that service: EAF066461
10. Vehicles for which the equipment is designed: PROJECT 615
11. Approval GRANTED
12. Reason(s) for extension of approval: Not applicable
13. Place: BRISTOL
14. Date: 22 JUNE 2005
15. Signature:  A.W. STENNING
Head of Product Certification
16. A list of documents contained in the approval file transmitted to the administrative service which has granted approval is annexed to this communication.

EAF066461





Vehicle Certification Agency

Far East Office

英國車輛驗證局遠東辦事處



建維驗證

VCA REFERENCES

Test Report Number **EAF066461**
Number of Pages **3**
Number of Annexes **3**

TEST DETAILS

Subject **Rear-view mirror**
Specific Requirements **ECE Reg. 81.00**
Sample size(s) **2**
Duration **2005/6/20~21**
Technical Service **Integrated Service of Quality Assessment for Vehicle Certification Agency**
VCA Representative **ARTHUR C H CHANG**
Manufacturer's Representative **Mr. Y.C. Lin**
Reason for Test **Type of Approval**

MANUFACTURER DETAILS

Manufacturer's Name **Fu Hwa Mirror Co.,Ltd**
Manufacturer's Address **688, Chang Lu Road, Sec. 7 Lukang, Chang-Hua, Taiwan, Republic of China**
Premise of Manufacturing **135, Fan-Gin Road, Pu-Yan, Chang-Hua Country, Taiwan, Republic of China**
Model Type & description **FP-318**
Category **L for Rear-view mirror**

CONCLUSION

The submitted samples are tested in accordance with Specific Requirements and found in compliance with all aspects.

Signature:

Name: **ARTHUR C H CHANG**

Position: **COE of ISOQA**

Date: **21 June 2005**

LIST OF ANNEXES

Annex	Total page	Subject	Reference
1	1	Information document	
2	2	Drawing & Photo	FP-318
3	1	Test Record	05-0155
4			





ECE REGULATION NO. 81

item	Parameter	RESULTS	YES/NO
6.	GENERAL REQUIREMENTS		
6.1.	All rear-view mirror shall be adjustable.		<u>YES</u>
6.2.	The edge of the reflecting surface shall be enclosed in a holder which, on its perimeter, shall have a value of "c" ≥ 2.5 mm at all points and in all directions. If the reflecting surface projects beyond the holder, the radius of curvature "c" of the edge of the projecting part shall be not less than 2.5mm and shall return into the holder under a force of 50N applied to the point of greatest projection relative to the holder in a horizontal direction approximately parallel to the longitudinal median plane of the vehicle.		<u>YES</u> <u>N/A</u>
6.3.	When the rear-view mirror is mounted on a plane surface, all its parts, irrespective of the adjustment position of the device, including those parts remaining attached to the holder after the test set out in paragraph 8.2., which are in potential static contact with a sphere 100 mm in diameter shall have a radius of curvature "c" of not less than 2.5 mm.		<u>YES</u>
6.3.1	Edges of fixing holes or recesses, which are less than 12 mm in width are exempt from the radius requirements of paragraph 6.3. provided they are blunted.		<u>N/A</u>
6.4.	The parts of rear-view dimensions of the a Shore A hardness not greater than 60 are exempt from the provisions set out in paragraphs 6.2. and 6.3. above.		<u>N/A</u>
7.	SPECIAL SPECIFICATIONS		
7.1.	<u>Dimensions</u>		
7.1.1.	The minimum dimensions of the reflecting surface must be such that:		
7.1.1.1.	The area shall not be less than 69 cm ² ,	<u>79.37cm² > 69 cm²</u>	<u>YES</u>
7.1.1.2.	In the case of circular mirrors, the diameter shall not be less than 94 mm,		<u>N/A</u>
7.1.1.3.	In the case of non-circular mirrors, the dimension will permit the inscription of a circle with a diameter of 78 mm on the reflecting surface.		<u>YES</u>
7.1.2.	The maximum dimensions of the reflecting surface must be such that:		
7.1.2.1.	In the case of circular mirrors, the diameter shall not be greater than 150 mm,		<u>N/A</u>
7.1.2.2.	In the case of non-circular mirrors, the reflecting surface shall fit into a rectangle measuring 120 mm by 200 mm.		<u>YES</u>
7.2.	<u>Reflecting surface and coefficient of reflection</u>		
7.2.1.	The reflecting surface of a rear-view mirror shall be spherically convex.		<u>YES</u>
7.2.2.	Differences between the radii of curvature:		
7.2.2.1.	he difference between ri or r' i and rp at each reference point shall not exceed 0.15 r.		<u>YES</u>
7.2.2.2.	The difference between any of the radii of curvature (rp1, rp2 and rp3) and r shall not exceed 0.15 r.		<u>YES</u>
7.2.3.	The value of "r" shall not be less than 1,000 mm nor greater than 1,500 mm.	Left = <u>1384</u> Right = <u>1345</u>	<u>OK</u> <u>OK</u>
7.2.4.	The value of the normal coefficient of reflection, determined according to the method described in annex 5 to this Regulation, shall not be less than 40%.	Left = <u>64%</u> Right = <u>61%</u>	<u>OK</u> <u>OK</u>
	If the mirror has two positions ("day" and "night"), the "day" position shall allow the colours of the signals used for road traffic to be recognised. The value of the normal coefficient of reflection in the "night" position shall not be less than 4%.		<u>N/A</u>
7.2.5.	The reflecting surface shall retain the characteristics specified in Paragraph 7.2.4., in spite of prolonged exposure to advance weather conditions, in normal condition of use.		<u>YES</u>
8.	TESTS		
8.1.	Rear-view mirrors, shall be subjected to the test described in paragraphs 8.2. and 8.3. below, to determine their behaviour under impact on and bending of the holder secured to the stem or support.		<u>YES</u>
8.2.	<u>Impact test</u>		<u>YES</u>
8.2.1.	Description of the test device:		
8.2.1.1.	The test device shall consist of a pendulum capable of swinging about two horizontal axes at right angles to each other, one of which is perpendicular to the front plane containing the "release" trajectory of the pendulum. The end of the pendulum shall comprise a hammer formed by a rigid sphere with a diameter of 165 ±1 mm and having a 5 mm-thick rubber covering of Shore A 50 hardness. A device shall be provided which permits determination of the maximum angle assumed by the arm in the plane of release. There shall be a support firmly fixed to the structure supporting the pendulum which serves to hold the specimens in compliance with the impact requirements stipulated in paragraph 8.2.2.6. below. Figure 1 below gives the dimensions of the test facility and the special design specifications.		<u>YES</u> <u>YES</u> <u>YES</u>
8.2.1.2.	The impact centre of percussion of the pendulum is identical with the centre of the sphere acting as the hammer. Its distance 'l' from the swing axis in the release plane is 1 meter ±5 mm. The reduced mass of the pendulum is m ₀ = 6,8 ±0,05 kg(m ₀ is linked to the total mass		<u>YES</u>





m of the pendulum and distance d between the centre of gravity of the pendulum and its axis of rotation via relation : $m_0 = m \frac{d}{l}$

8.2.2. Description of test

- 8.2.2.1. The procedure used to clamp the rear-view mirror to the support is recommended by the manufacturer of the device, or, where appropriate, by the vehicle manufacturer. YES
- 8.2.2.2. Positioning of the rear view mirror for the test. YES
- 8.2.2.2.1 Rear-view mirrors shall be positioned on the pendulum impact rig such that the axes, which are horizontal and vertical when installed on a vehicle in accordance with the vehicle or rear-view mirror manufacturers' mounting instructions, are in a similar position. YES
- 8.2.2.2.2 When a rear-view mirror is adjustable in relation to the base, the test position shall be the least favorable for any pivoting device to operate within the limits provided by the mirror or vehicle manufacturer. YES
- 8.2.2.2.3 When the view mirror can be moved closer to or away from its base, the relevant device shall be placed in the position in which the distance between the housing and base is shortest N/A
- 8.2.2.2.4 When the reflecting surface can be moved within the housing, its setting shall be such that the upper edge furthest from the vehicle shall be in the most protruding position in relation to the housing. N/A
- 8.2.2.3. When the pendulum is in a vertical position, the horizontal and longitudinal vertical planes passing through the centre of the hammer, shall pass through the centre of the mirror as defined in paragraph 2.7. above. The longitudinal direction of oscillation of the pendulum shall be parallel to the longitudinal plane of the vertical. YES
- 8.2.2.4. When, under the conditions governing adjustment prescribed in paragraph 8.2.2.2.1 and 8.2.2.2.2, above, parts of the rear-view mirror limit the return of the hammer, the point of impact shall be shifted in a direction perpendicular to the axis of rotation or pivot in question. This displacement shall be that which is strictly necessary to the implementation of the test. YES
It shall be limited in such a way that the point of contact of the hammer is located at least 10 mm from the periphery of the reflecting surface. YES
- 8.2.2.5. The test consists of releasing the hammer from a height corresponding to a pendulum angle of 60 degrees to the vertical in such a way that the hammer strikes the rear-view mirror at the moment when the pendulum reaches the vertical position. YES
- 8.2.2.6. The rear-view mirrors are subjected to impact in the following different conditions: YES
- 8.2.2.6.1 Test-1: The point of impact shall be as defined in paragraph 8.2.2.3 or 8.2.2.4 The impact shall be such that the hammer strikes the rear-view mirror on the reflecting surface side. YES
- 8.2.2.6.2 Test-2: The point of impact shall be as defined in paragraphs 8.2.2.3 or 8.2.2.4. The impact shall be that the hammer strikes the rear-view mirror on the opposite side to the reflecting surface. YES
- 8.3 **Bending test on the protective housing fixed to the stem**
- 8.3.1. *Description of the test*
- 8.3.1.1. The holder shall be placed horizontally in a device in such a way that the adjustment parts of the mounting can be clamped securely. In the direction of the greatest dimension of the holder, the end nearest to the point of fixing on the adjustment part shall be immobilized by means of a fixed step 15 mm wide, covering the entire width of the holder. YES
- 8.3.1.2. At the other end, a stop identical to the one described above shall be placed on the protective housing so that the specified test load can be applied to it (see figure 2 below). YES
- 8.3.1.3. The end of the protective housing opposite that at which the force is applied may be clamped instead of kept in position as shown in Figure 2. YES
- 8.3.2. The test load shall be 25 kg applied for one minute. YES
- 8.4. **Results of the tests**
- 8.4.1. In the tests described in Paragraph 8.2., the pendulum must continue to swing after impact in such way that the projection of the position taken by the arm on the release plane makes an angle of at least 20° with the vertical.

	<u>Test 1</u>	<u>Test 2</u>	
Left	<u>51°</u>	<u>52°</u>	<u>OK</u>
Right	<u>51°</u>	<u>51°</u>	<u>OK</u>
- 8.4.1.1 The accuracy of the angle measurement shall be ±1°. YES
- 8.4.2. The mirror shall not break during the tests described in Paragraph 8.2. and 8.3. However, breakage of the mirror shall be allowed if one of the following conditions is fulfilled: No breakage of rear view mirror
- 8.4.2.1. The fragments of glass still adhere to the back of the protective housing or to a surface firmly attached to the protective housing, except that partial separation of the glass from its backing is permitted, provided this does not exceed 2.5 mm either side of the crack. It is permissible for small splinters to become detached from the surface of the glass at the point of impact.
- 8.4.2.2. The mirror is made of safety glass.



Fu-Hwa Mirror Co., Ltd.

福華明鏡股份有限公司

Information Document

for Initial application to ECE Homologation
of Model Number FP-318

items	Details	Initial	Extension-	00	Remark
1.	VCA				
1.1	Job Number	EAF066461			
1.2	Approval Number	00 1094			
2.	Manufacturer				
2.1	Name	Fu-Hwa Mirror Co., Ltd.			
2.2	Address	688 Chang-Lu Road, Sec. 7, Lukang, Chang-Hwa Hsien, Taiwan, R.O.C.			
2.3	Trade name or mark	FU			
3.	Product				
3.1	Model Number	FP-318			
3.2	Intended functions	Charteristic			
3.2.1	Rear-view Mirror (Reg. 81)	Category	L		
		Radius of Curvature	1250±150		
		Mounting Instruction	Shaft-screw drive into handbar-holder.		
		Applicable Vehicle	PROJECT 615		
4.	Drawings	FH-318			

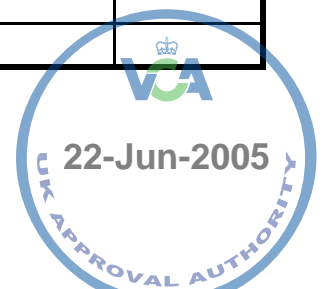

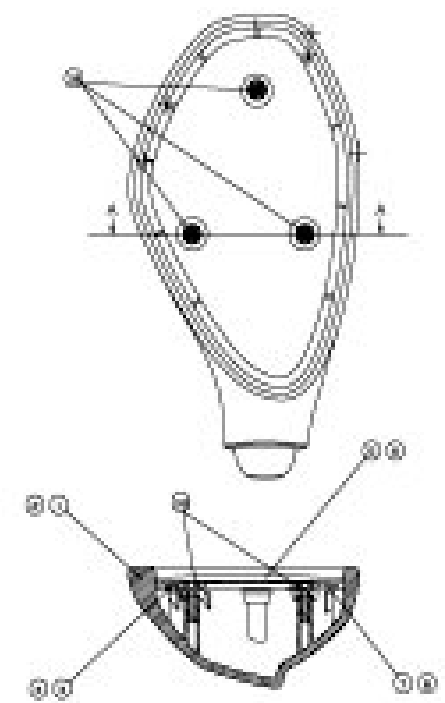
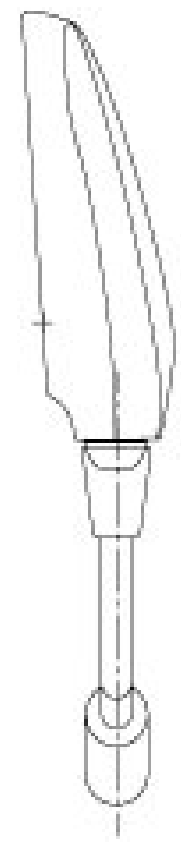
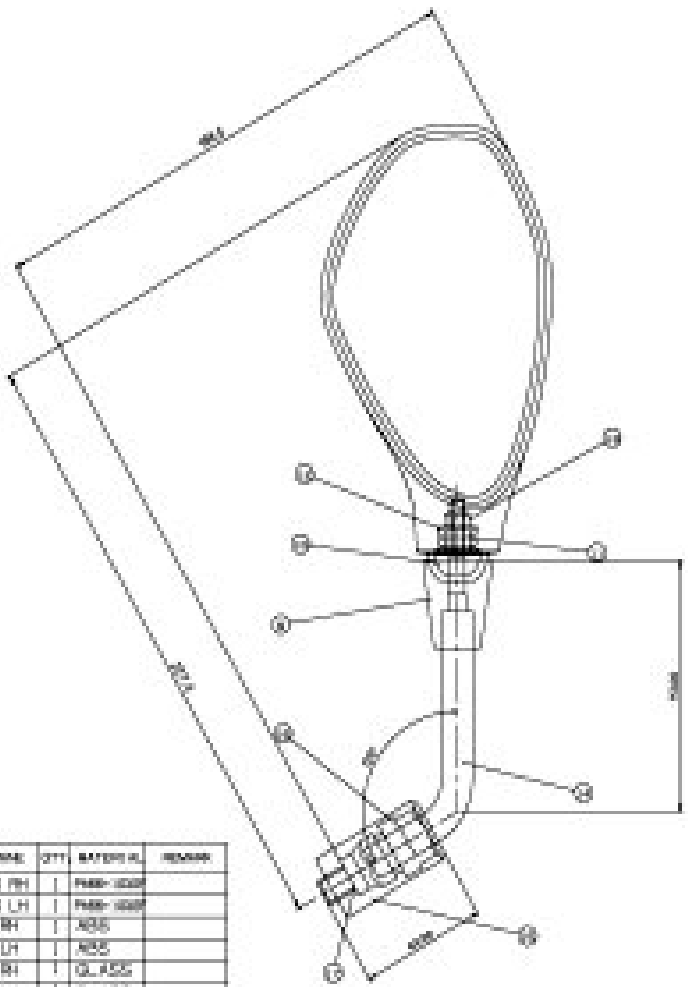

SECTION B-A

PART NO.	REV.	PART NAME	QTY	MATERIAL	REMARK
BP01B0400	1	HILT MG RH	1	PH88-300P	
BP01B0400	2	HILT MG LH	1	PH88-300P	
BP01B0400	3	HOLDER RH	1	ASS	
BP01B0400	4	HOLDER LH	1	ASS	
BP01B0400	5	MIRROR RH	1	GLASS	
BP01B0400	6	MIRROR LH	1	GLASS	
BP01B0400	7	TAPC RH	1	PC1	
BP01B0400	8	TAPC LH	1	PC1	
BP01B0400	9	CAP LOCK	1	PH88-300P	
BP01B0400	10	RECTANGLE	1	SS304	
BP01B0400	11	SPRING	1	SPR	
BP01B0400	12	BARRIER	1	SPCC	
BP01B0400	13	U-NUT	1	SPRM	NO
BP01B0400	14	STAY	1	SS304	
BP01B0400	15	SCREWS	1	SPRM	
BP01B0400	16	BASE A	1	1.2L 14	all in green color
BP01B0400	17	BASE B	1	1.2L 14	all in green color
BP01B0400	18	SCREW	3	SPRM	same as

DATE: 14 JUN 2005 15:58:18

NO.	NAME	DESIGNER	CHECKER	DATE
1	PROJECT	PROJECT	PROJECT	22 JUN 2005
2	PROJECT	PROJECT	PROJECT	22 JUN 2005

APPROVAL AUTHORITY

福華明鏡股份有限公司

Fu-Hwa Mirror Co., Ltd.

FP-318 Product:Rear-View Mirror

Front View (LH)



Front View (RH)



Rear View (LH)



Rear View (RH)



Mirror (LH)



Mirror (RH)

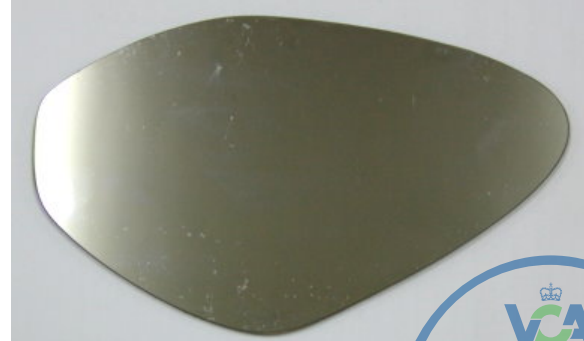

Test Record

Record No.	05-	0155	Ref.	EAF066461	81	00 1094
Requirement	ECE Regulation 81			Clause	C7&8	
Subject	FP-318			Date	6/20~21/2005	

test sample		Curvature(7.2)					C= 63.25 mm =distance between sta						
		hight measured					curvature						
		hx	hy	ri	r'i.	rp	r	0.15r	difference between	ri-rp	rp1-r	rp2-r	rp3-r
1 (left)	p1	0.334	0.381	1,497	1,313	1,405	1,384	208		92	21	2	19
	p2	0.340	0.387	1,471	1,292	1,381				89			
	p3	0.352	0.382	1,421	1,309	1,365				56			
2 (right)	p1	0.332	0.398	1,506	1,256	1,381	1,345	202		125	36	13	23
	p2	0.356	0.397	1,405	1,260	1,332				73			
	p3	0.369	0.388	1,355	1,289	1,322			33				
test sample	Coefficient of reflection(7.2.4)					Impact test(8.2)		area≥69cm ² (7.1.1.1)	Bending Test (8.3)				
						Test 1	Test 2						
1 (left)	64%					51°	52°	79.4	OK				
2 (right)	61%					51°	51°	79.4	OK				

Witnessed by Huijen Lai

Signature *Huijen Lai*

Approved by Arthur C. H. Chang

Signature *Arthur Chang*

