



# **INSTALLATION & USER'S GUIDE**

**Adventure TorqDrive® Clutch**

For KTM 690 / Husqvarna 701 Enduro &  
Duke Manual Clutch

Doc ID: 191-2880A

Revision: 071222

# **TABLE OF CONTENTS**

OVERVIEW .....	2
INSTALLATION TIPS .....	2
TOOLS NEEDED.....	3
INCLUDED PARTS .....	4
DISASSEMBLE THE CLUTCH .....	5
ASSEMBLE THE CLUTCH PACK.....	9
CLUTCH PACK INSTALLATION.....	13
BREAK-IN.....	17
TROUBLESHOOTING.....	17
Clutch Drag .....	17
Clutch Slip .....	17
MAINTENANCE.....	18
Disk inspection examples .....	19
NEED ADDITIONAL HELP?.....	20

## **OVERVIEW**

This guide shows you how to replace your OE (Original Equipment) or “stock” clutch parts with your new Rekluse TorqDrive<sup>®</sup> clutch parts. The following parts are replaced:

- OE Drive Plates
- OE Friction Disks





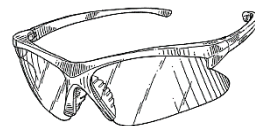

## **INSTALLATION TIPS**

- Read the separate included Safety Information document before operating the vehicle with the product installed.
- Read this entire document before performing any steps.



- If you install this product for a customer or another person, instruct them to read the **Safety Information** document and the **Installation and User Guide** before operating the bike with the product.
- Protect eyes and skin – wear safety glasses and work gloves.
- Lay the motorcycle on its left side when replacing the clutch. This makes working on the clutch easier and eliminates the need to drain the oil. Catch any fuel that may drain from the bike.
- Use the torque values listed in the instructions. Otherwise, use the torque specifications found in your OE service manual.
- For optimal clutch performance Rekluse recommends using fresh, clean oil that **meets JASO-MA** oil rating requirements. Rekluse offers Factory Formulated Oil™ developed specifically for Rekluse products. Rekluse Factory Formulated Oil is a perfect complement to any OEM or aftermarket wet clutch. Visit [www.rekluse.com](http://www.rekluse.com) to learn more.

## **TOOLS NEEDED**

	 8 mm	 10 mm	
Fluid Catch Container	8 mm Socket	10 mm Socket	Torque Wrench
  4 mm			
4 mm Allen Wrench	30 mm Socket		

# **INCLUDED PARTS**

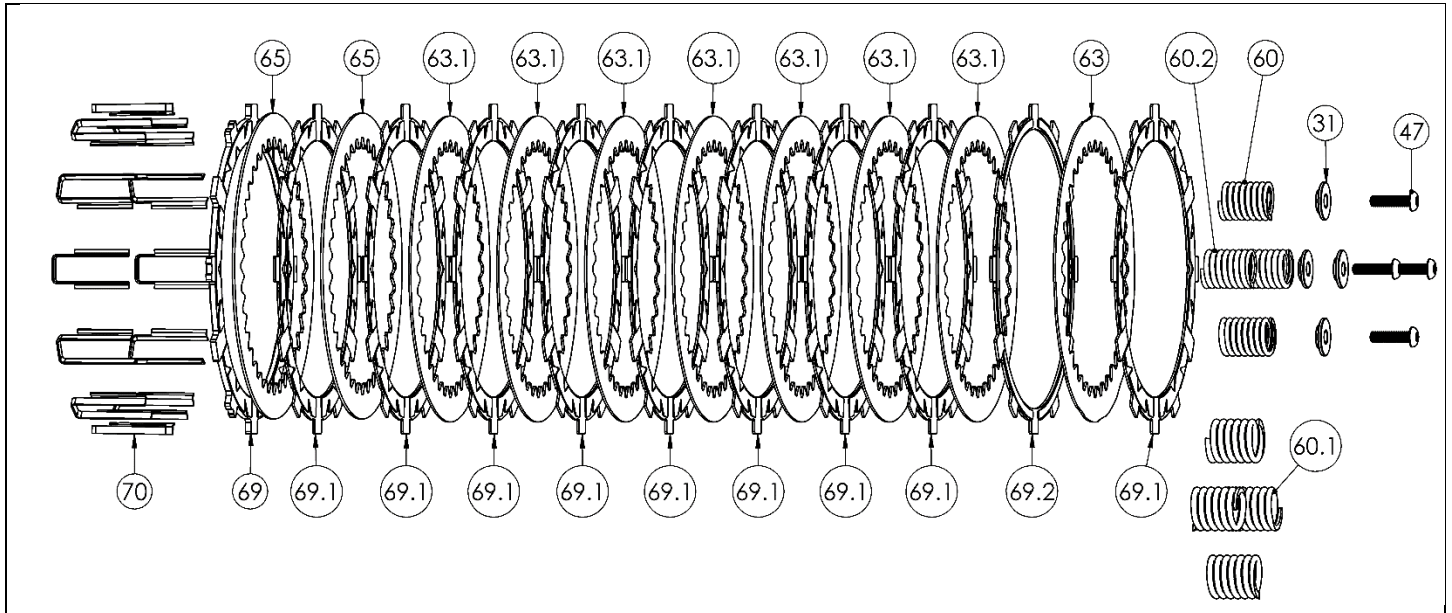

<b>Item</b>	<b>Description</b>	<b>Qty.</b>
31	Screw Sleeves	4
47	Pressure Plate Screws	4
60	Pressure Plate Springs – Silver (2019+ models)	2
60.2	Pressure Plate Springs – Green (2019+ models)	2
60.1	Pressure Plate Spring – Orange (2008-2018 models)	2
63	Steel Drive Plate (.040 in) – Wavy OD	1
63.1	Steel drive plates (.040 in)	7
65	Thick steel drive plates (.048 in)	2
69	Thick TorqDrive® friction disk (thick)	1
69.1	TorqDrive® friction disks (thin)	9
69.2	TorqDrive® friction disks (thin judder)	1
70	Basket sleeves	12
Not Shown	Assembly screws (to aid assembly only - Must be removed before use!)	2

Visit [www.rekluse.com/support](http://www.rekluse.com/support) for a full parts fiche illustration and part numbers.

# **DISASSEMBLE THE CLUTCH**

1. Soak the Rekluse friction disks in new oil for at least 5 minutes. Make sure the friction disks are coated on both sides.

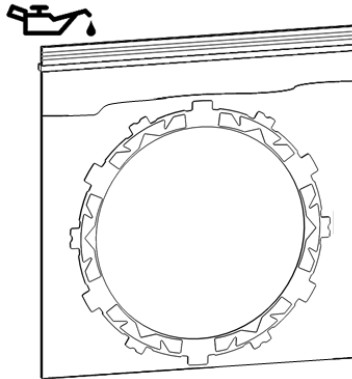

2. Prepare the bike for the installation. Lay the bike on its left side to eliminate draining the oil.
  - If you prefer, you can stand the bike on its center stand and drain the oil.



3. Use a socket to remove the right side swingarm bolt, then move the foot peg assembly out of the way of the clutch cover bolts and clutch cover.
4. Use an 8 mm socket to remove the oil filter cover from the engine and move it up out of the way.

5. Use an 8 mm socket to remove the clutch cover, being careful not to damage the cover gasket. *Pay close attention to the length and location of the OE screws so they can be returned to their same location.*



6. Remove the OE bolts, spring ring (2019+), and springs. Then remove the pressure plate and throw-out.

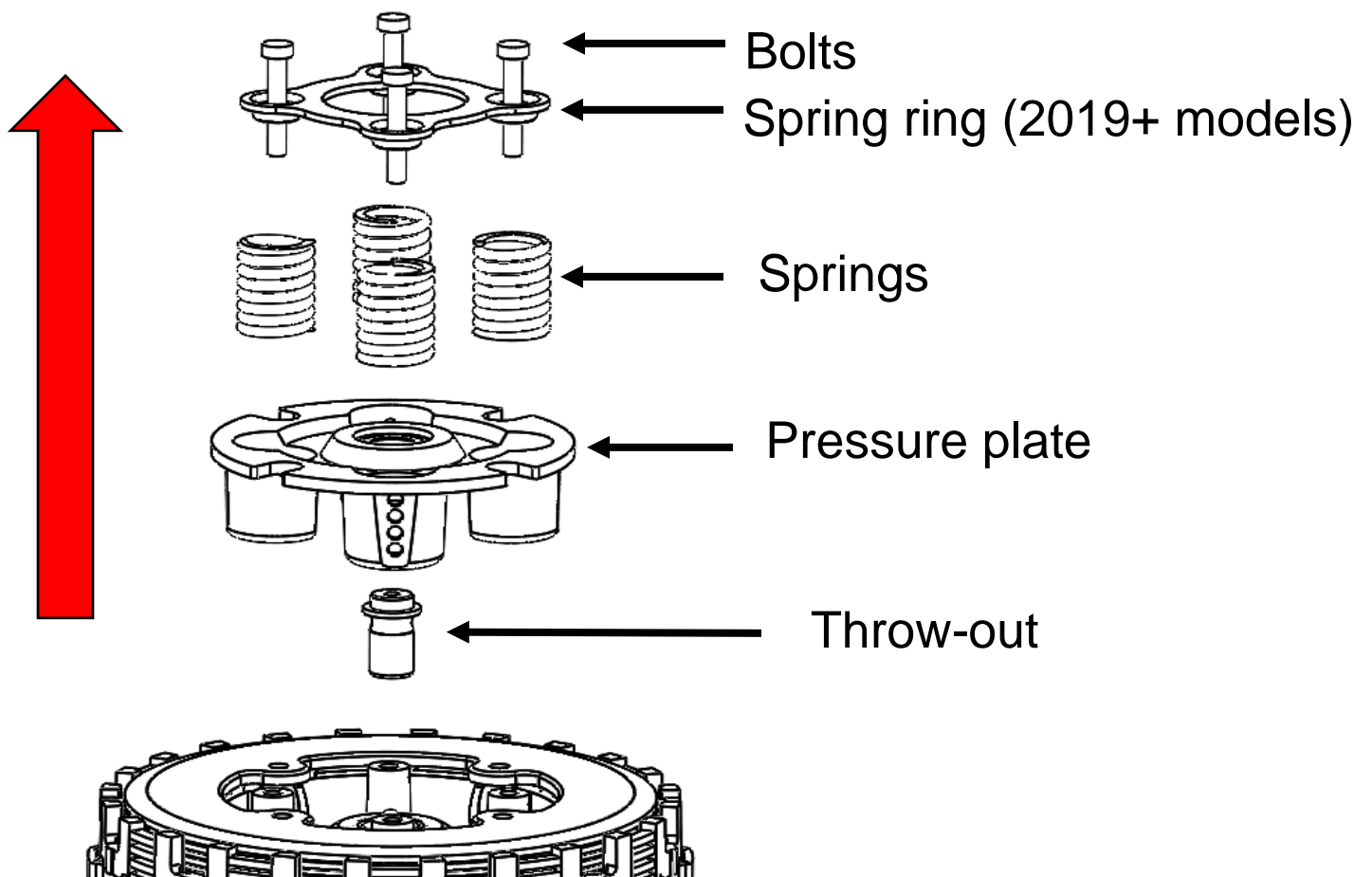

**NOTICE**

*The bolts, spring ring, and springs will not be reused and can be set aside*

7. Remove the outer hub, the judder spring and seat, the hub springs, and the entire OE clutch pack.

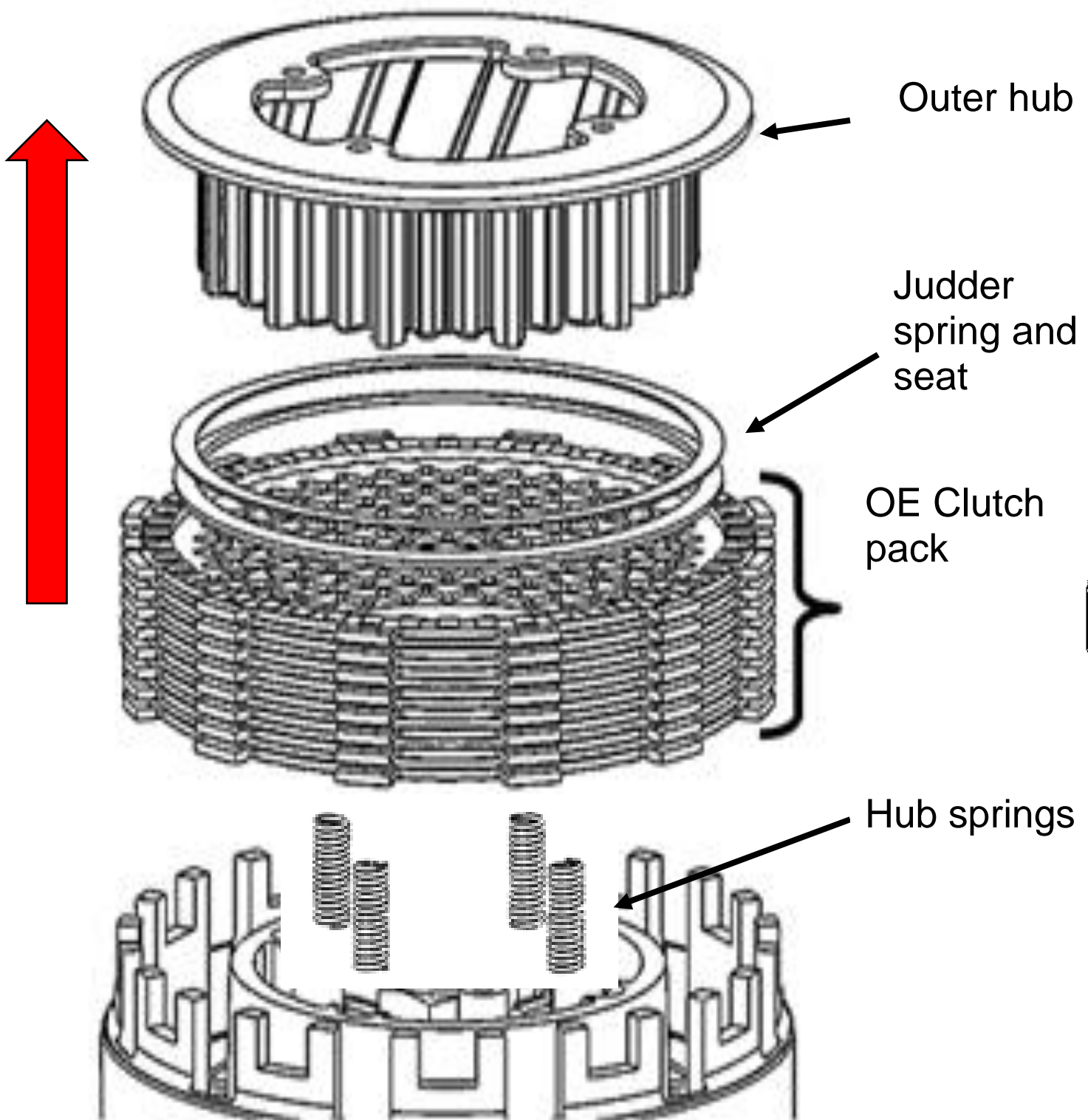

**⚠ CAUTION**

***If the judder spring and seat are missing, check to see if they are stuck to the outer hub. The judder spring will be reused while the judder seat will not be reused. Failure to remove these parts before installing the Rekluse clutch pack will result in poor performance or clutch malfunction.***

8. Use a socket to remove the center clutch nut with an impact wrench or breaker bar. Set aside. The OE clutch nut will be reused.

## NOTICE

*Placing the bike in the highest gear and holding the rear wheel keeps the shaft from rotating when removing the nut.*

9. Remove the washer located under the center clutch nut, then remove the inner hub.

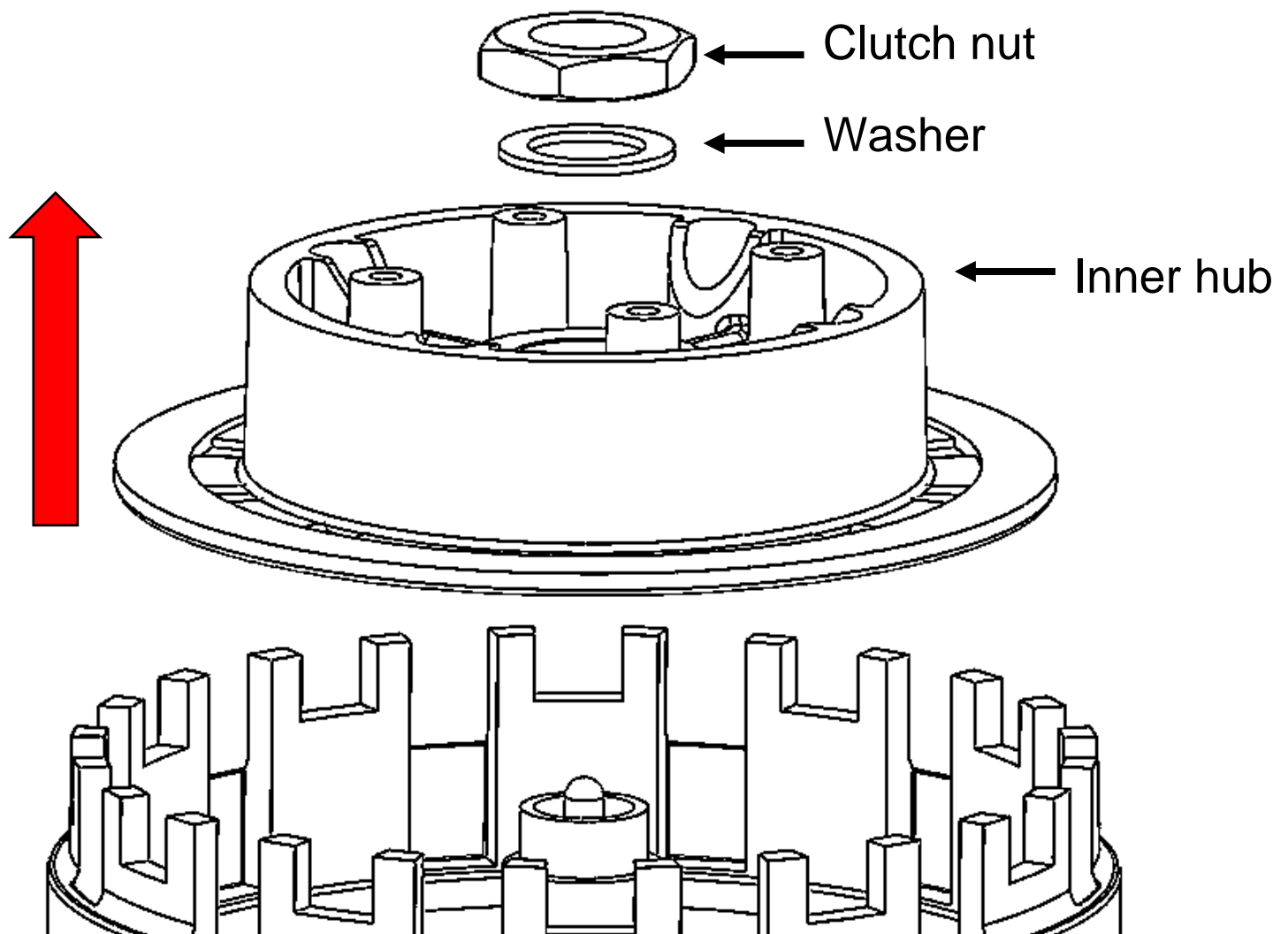

# **ASSEMBLE THE CLUTCH PACK**

**See Setup Sheet at end of manual for reference.**

The Rekluse clutch pack is assembled between both hubs before it is installed in the clutch basket.

## **NOTICE**

*Some friction disks are marked with a small colored dot. This mark is used for processing and can be ignored.*

1. Before you begin assembling the clutch, locate the alignment arrows on the backside of the OE hubs. These arrows need to line up when the clutch is assembled for the clutch to function properly.
2. Separate the thicker friction disk from the other friction disks. Put it aside. This friction disk is installed last.

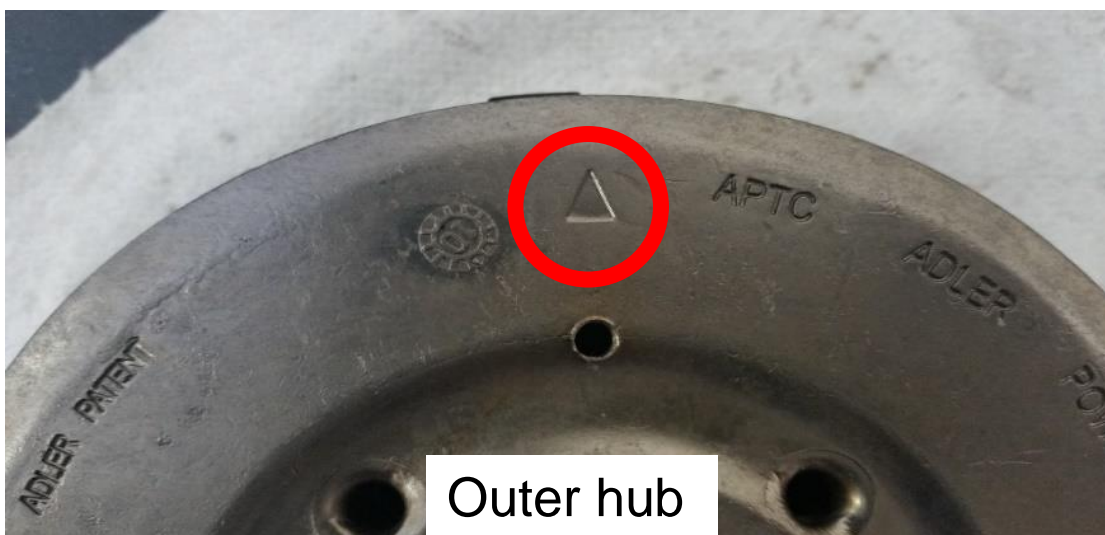

3. Place the outer hub upside down on a clean workbench.
4. Install a **thin** friction disk, then install the steel drive plate with the wavy OD.
5. Install the **thin judder** friction disk with the larger OD, then install the OE judder spring, cupped side up.
6. Install a steel drive plate, then a **thin** friction disk. Alternate steel drive plates and **thin** frictions, ending in a steel drive plate.
7. Install the **thick** friction disk last.

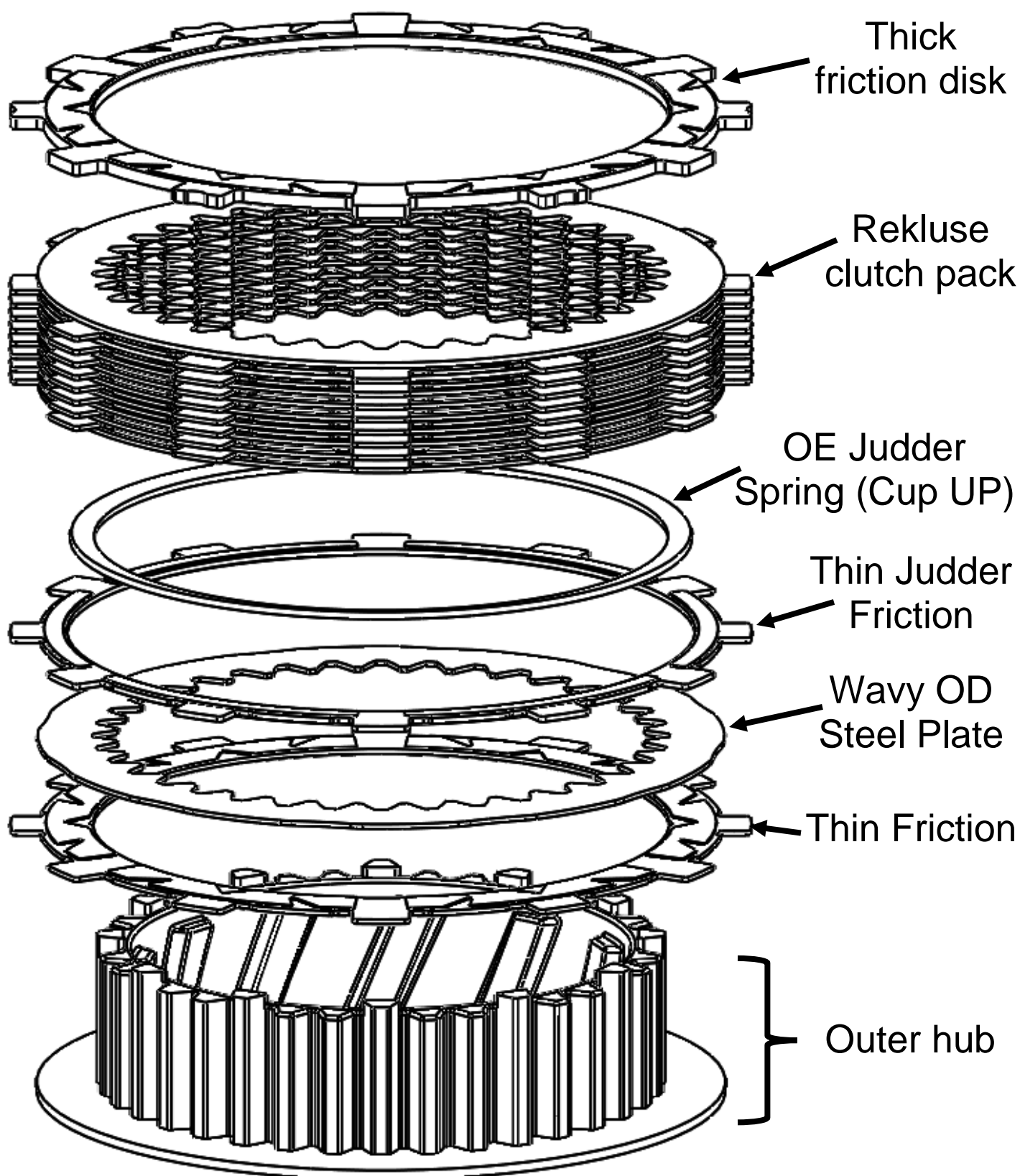

8. Place the 4 OE hub springs in their pockets in the outer hub.

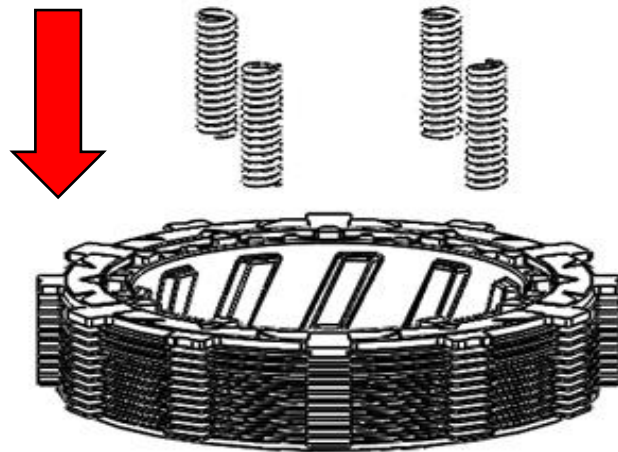

9. With the outer hub assembly on a bench surface, insert the inner hub into the assembly, lining the arrows up to form one assembly. *If the arrows are not lined up, the clutch pack may not function properly.*



Outer hub



Inner hub

10. Use your hands to compress the assembly together, then flip it over so that the outer hub is facing up.

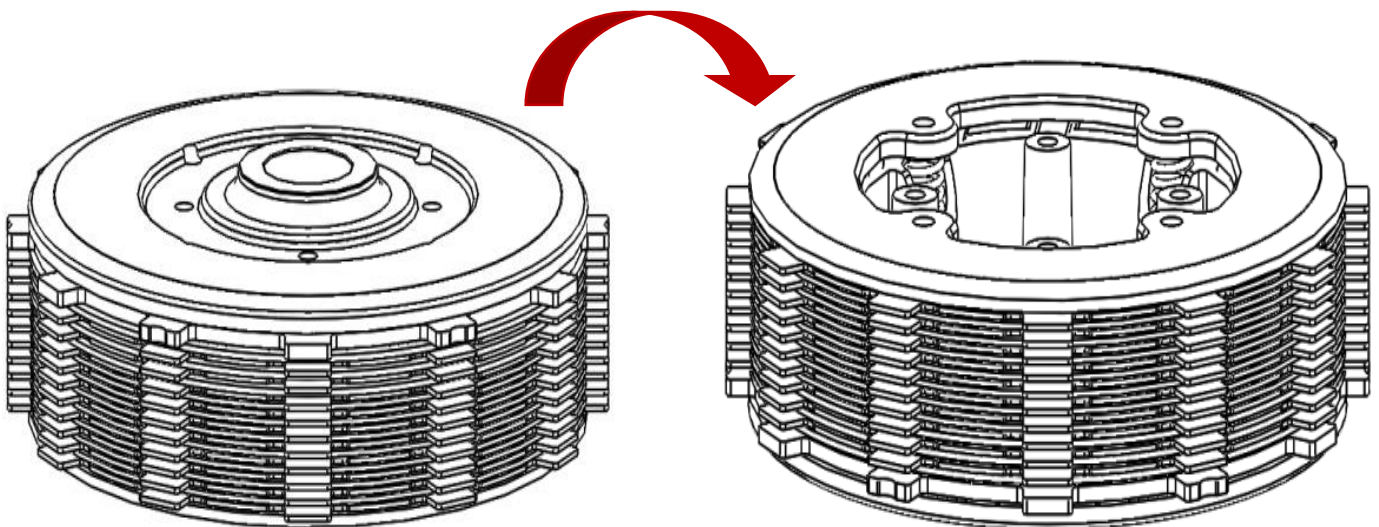

11. Thread the 2 provided assembly screws through opposite spring pockets.

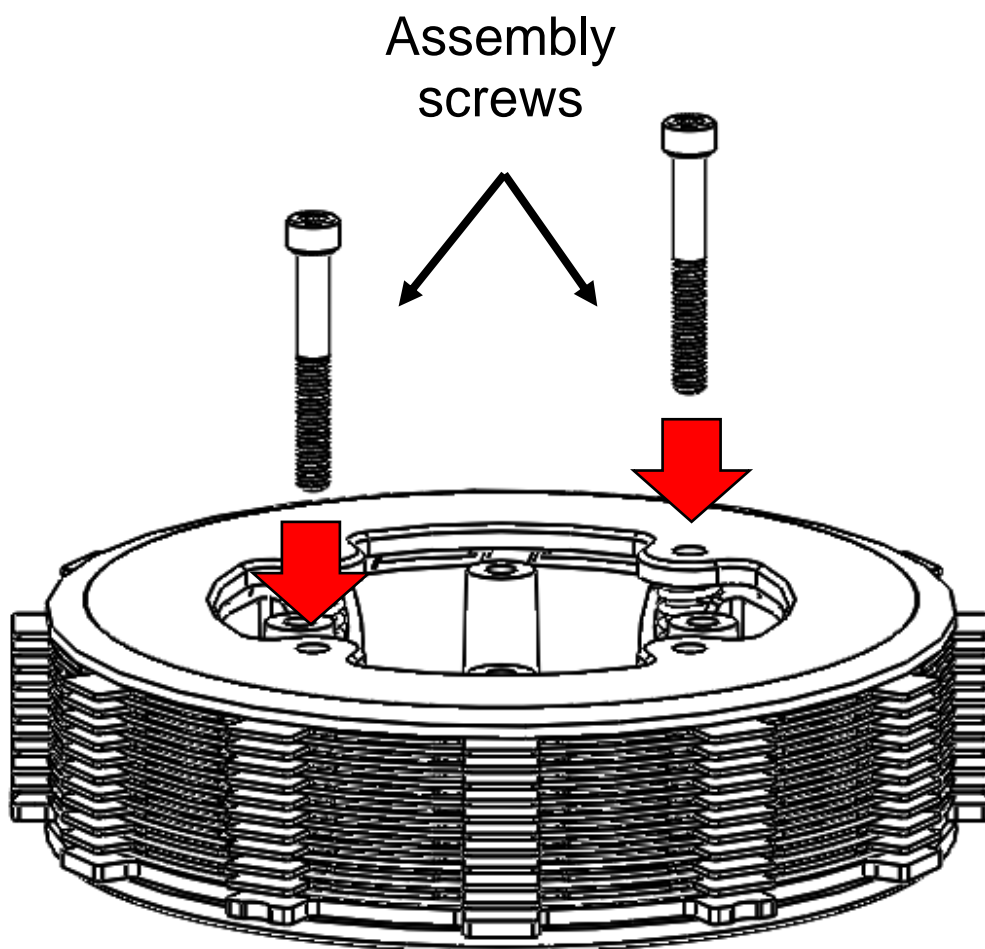

12. Use a 4 mm Allen wrench to tighten the screws so the springs are slightly compressed and holds the clutch pack between the 2 hubs.

### NOTICE

***Do not over-tighten!*** This step is designed to make it easier to drop the hub assembly into the clutch basket as one unit. The screws will be removed in a later step.

# **CLUTCH PACK INSTALLATION**

1. Inspect the clutch basket for spring damper play or notching. Do not install sleeves or use product with a notched basket. Notched basket tang faces or worn spring dampers can cause the sleeves to break.

## **⚠ WARNING**

**Failure to inspect the basket and replace if necessary could result in death, serious injury, and/or property damage.**

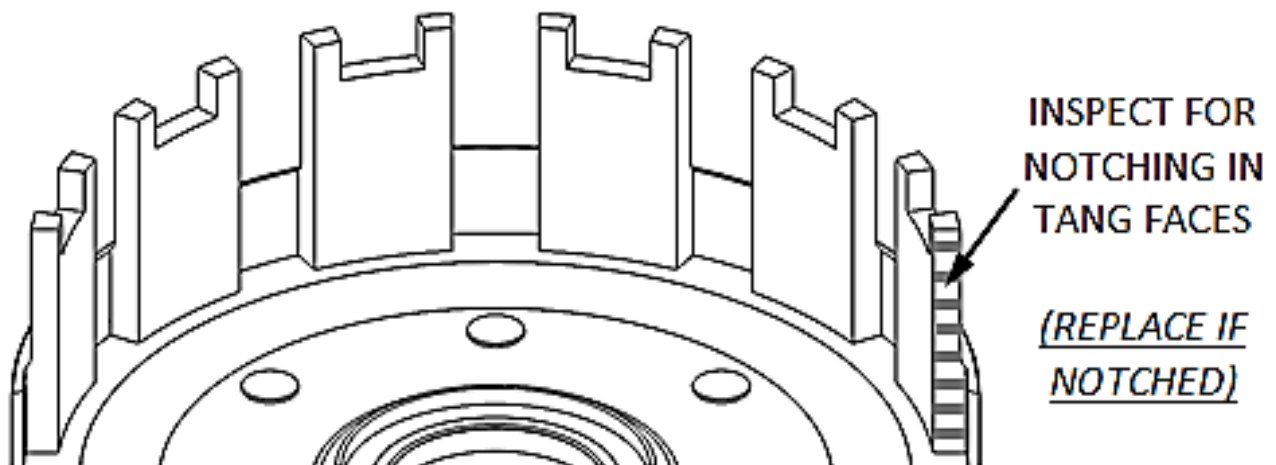

2. Install all of the Rekluse basket sleeves into the basket slots. Make sure the bottom of the sleeve is facing down, and the sleeve tabs sit against the inside of the basket. See following pictures for reference.

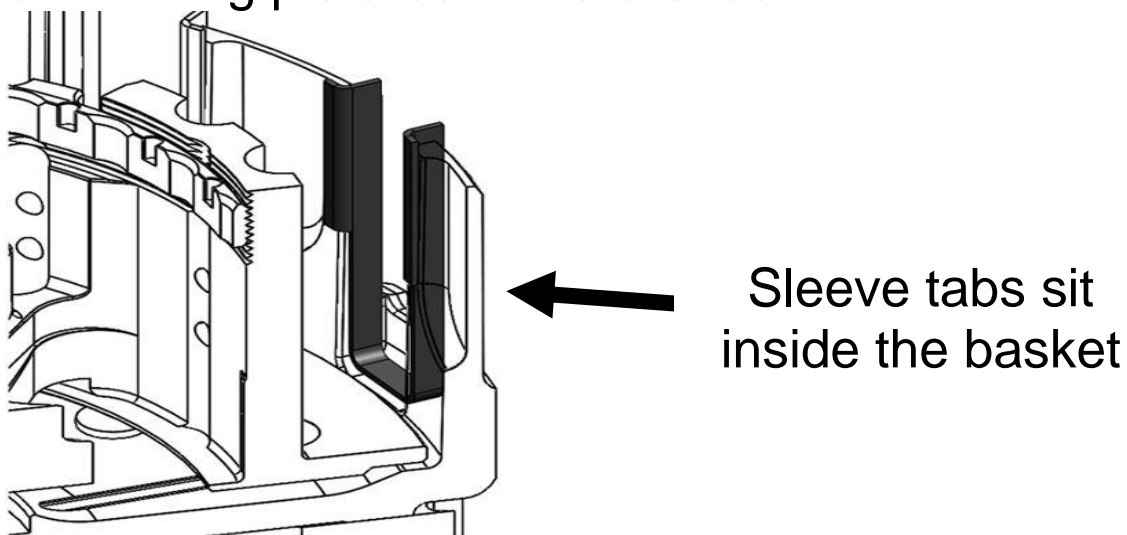

## **⚠ WARNING**

**Rekluse basket sleeves are designed to be installed into an OE or Rekluse clutch basket ONLY. The use of non-Rekluse aftermarket clutch baskets may cause clutch damage or failure.**

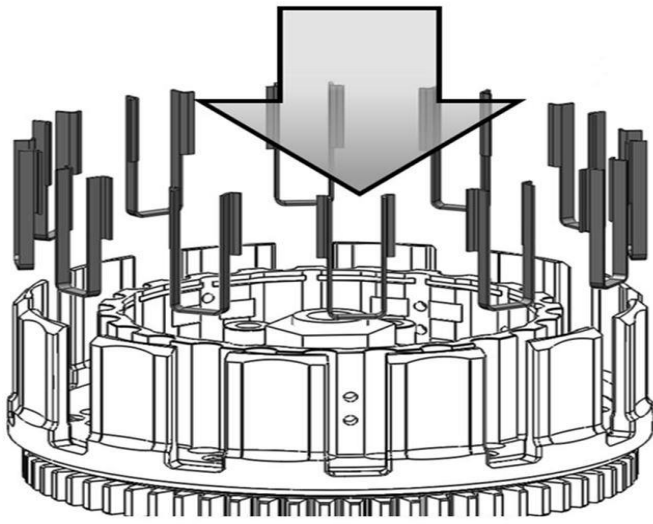

Install all the  
basket sleeves

*When seated in the basket, the sleeve tops will sit flush with the top of the basket.*

**NOTICE**

3. Check the clutch basket to ensure the 3-piece thrust washer is correctly assembled in place on the mainshaft. *(These may have moved when the hubs were removed from the bike.)* If they have shifted, position them correctly before continuing to the next step.

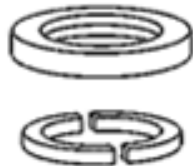

Thrust washers

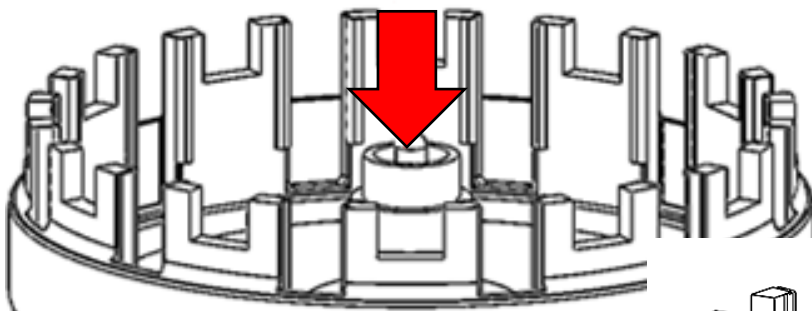

Cross-section view

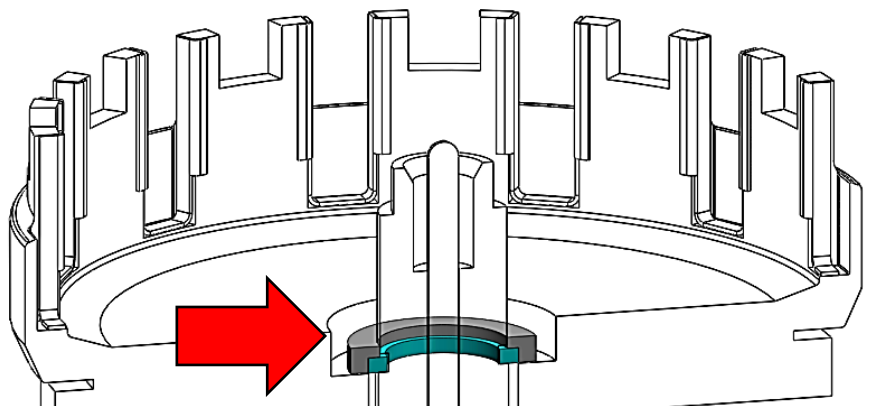

4. Install the hub assembly into the clutch basket with the assembly screws facing up. Make sure to place the friction disk tabs into the steel basket sleeves and the inner hub spline indexes correctly to the mainshaft.

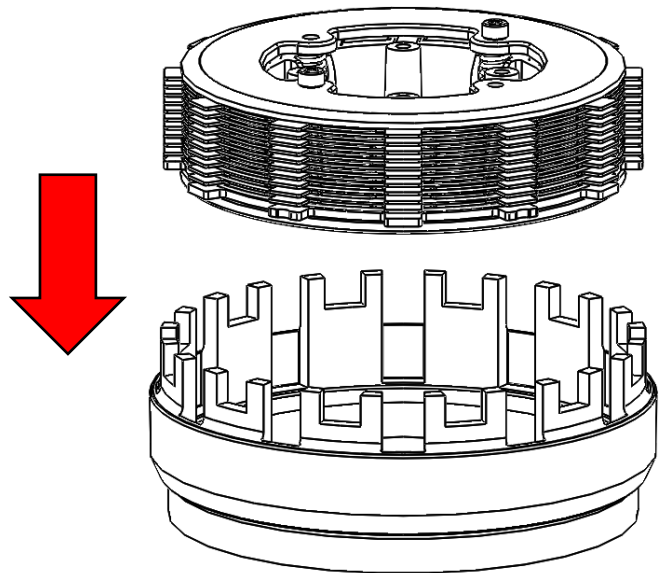

5. Reinstall the OE washer and center nut, applying Loctite© 243 or equivalent thread-locking compound to the threads.
6. Use a torque wrench to tighten the center nut to 74 ft-lb (100 N-m).

**CAUTION**

***Do not over-torque the center clutch nut. Over-torqueing will cause drag and can damage your engine's bearings or transmission components.***

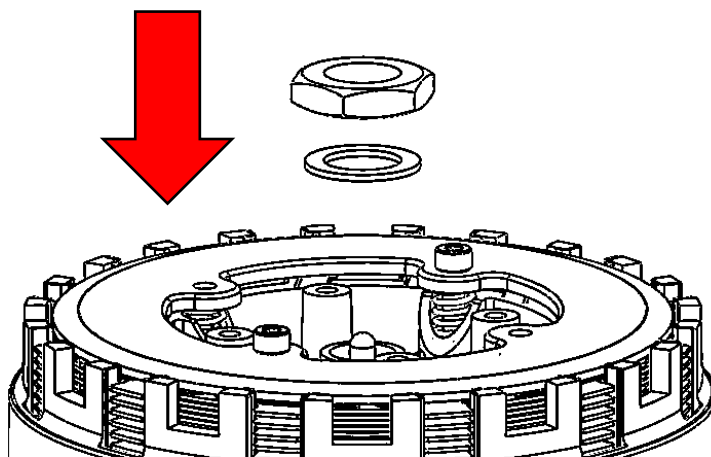

**NOTICE**

***Placing the bike in the highest gear and holding the rear wheel keeps the shaft from rotating when tightening the nut.***

7. Reinstall the OE throw-out and pressure plate.

8. Install the new Rekluse pressure plate springs, Rekluse screw sleeves, and Rekluse pressure plate bolts. **For 2008-2018 models, use all orange springs. For 2019 and newer models, use 2 green and 2 silver springs, alternating spring colors when installing. Do not reuse the OE spring ring.**

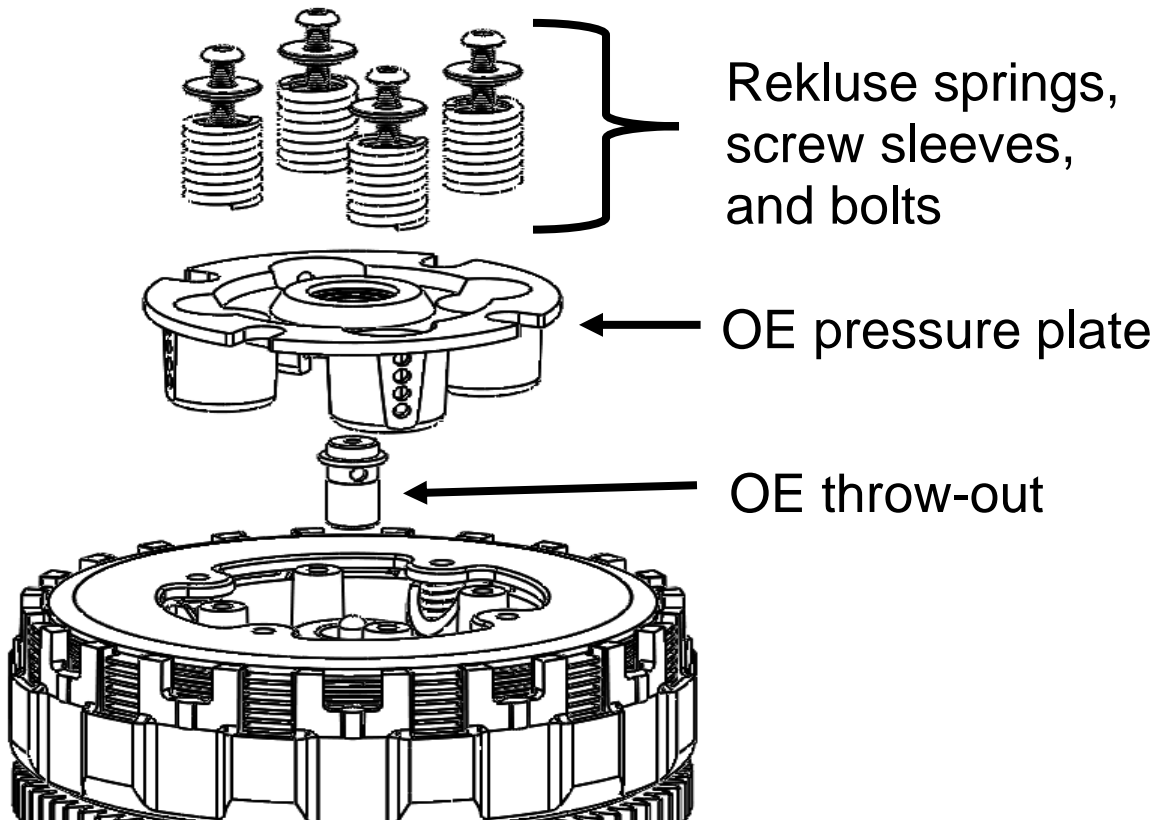

9. Torque pressure plate bolts in small increments to 4.4 ft-lb (6 N-m) as per OE specifications.
10. Use the 4 mm Allen wrench to remove the assembly screws used during installation.

**⚠ CAUTION**

***The assembly screws **MUST BE REMOVED** or engine damage will occur.***

11. Reinstall the clutch cover by lightly tightening the cover bolts in a star pattern. Torque the bolts in small increments to 7.4 ft-lb (10 N-m) as per OE specifications.
12. Reinstall oil filter cover and torque the bolts to 4.4 ft-lb (6 N-m).
13. Reinstall the foot peg assembly and swingarm bolt, applying thread-locking compound to the swingarm bolt and torque to 59 ft-lb (80 N-m).

## **BREAK-IN**

Break-in will occur over the first 1-2 hours of use, depending on the rider. During break-in more clutch drag may occur than normal.

## **TROUBLESHOOTING**

### **Clutch Drag:**

- Cold Drag Only – If drag occurs only while the bike is cold, oil is the most likely cause. Be sure to warm up the bike before riding/racing. Use of lighter weight oil can help to minimize cold drag.
- Hot and Cold Drag – Ensure that the center clutch nut is properly torqued so that the center clutch spins freely. Check for any warped steel drive plates or frictions in the clutch pack.

### **Clutch Slip:**

- If clutch slip occurs, inspect the clutch for signs of wear or heat.

# **MAINTENANCE**

To keep your clutch performing at its best, perform regular maintenance on your bike and clutch. Clutch longevity and performance is greatly increased with oil quality and other bike factors that reduce engine heat.

- Inspect all of your clutch parts at regular maintenance intervals for signs wear or excessive heat, and replace components as necessary. Clutch wear is dependent on the riders use.
- Inspect and replace basket sleeves if they appear to be notched from friction disks.
- Replace friction disks if they are glazed and/or burnt.
- Keep up with regular oil changes as per the bike manufacturer's recommendations. Clutch performance and longevity depend on oil quality.
- For optimal clutch performance Rekluse recommends using fresh, clean oil that **meets JASO-MA** oil rating requirements.

## Disk inspection examples

When inspecting the clutch pack, the following pictures can be used as a reference. **These are best viewed in color by viewing this install document at [www.rekluse.com/support](http://www.rekluse.com/support).**

**Drive Plates** – If the clutch pack is getting high amounts of heat, purple, blue, or black color can be seen on the drive plate teeth. See pictures below. Not all drive plates look the same and may look different than pictured.



Normal Heat

High Heat  
(Blue)

Excessive Heat  
(Black)

**Friction Disks** – Due to the dark color of the friction material, the friction disks will appear almost black as soon as they are put in oil. During inspection, look for glazing of the friction material. Glazing will appear shiny and feel like glass, even after oil is cleaned from the friction disk. Not all friction disks look the same and may look different than pictured.



Normal  
Friction



Glazed  
Friction

# **NEED ADDITIONAL HELP?**

## **Website**

[www.rekluse.com/support](http://www.rekluse.com/support)

## **Frequently asked questions**

[www.rekluse.com/faq](http://www.rekluse.com/faq)

## **Support Videos**

[www.rekluse.com/support/videos](http://www.rekluse.com/support/videos)

## **Phone**

(208) 426-0659

## **Technical Support**

Contact Technical Support for questions related to product installation, tuning, and performance.

### **Hours:**

Monday thru Friday: 8:00 a.m. - 5:00 p.m.

Mountain Time zone

Email: [tech@rekluse.com](mailto:tech@rekluse.com)

## **Customer Service**

Contact Customer Service for additional product information, orders, and returns.

### **Hours:**

Monday thru Friday: 8:00 a.m. - 5:00 p.m.

Mountain Time zone

Email: [customerservice@rekluse.com](mailto:customerservice@rekluse.com)

# SETUP SHEET 198-2813080

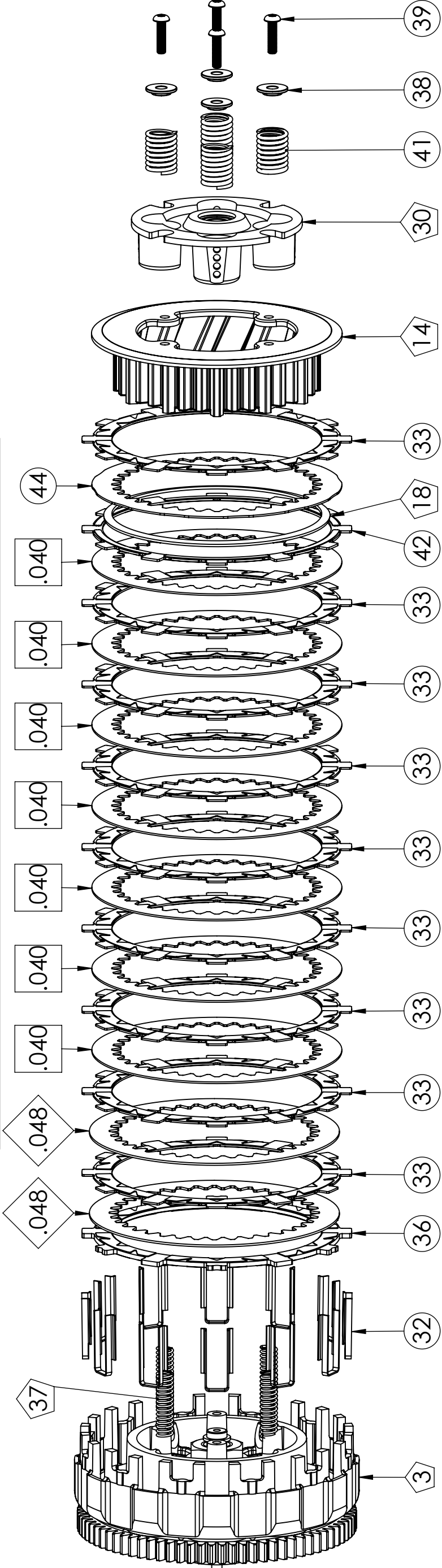

ITEM NO.	PART DESC.	QTY.
3	OE BASKET AND INNER HUB	1
14	OE OUTER HUB	1
18	OE JUDDER SPRING	1
30	OE SPRING PLATE	1
32	BASKET SLEEVE	12
33	TORQDRIVE FRICTION - .070" THICK	9
36	TORQDRIVE THICK FRICTION - .137" THICK	1
37	OE SLIPPER SPRING	4
38	SCREW SLEEVE	4
39	PP SCREWS - T25 TORX	4
41	*PP SPRINGS - SEE CHART*	4
42	TORQDRIVE FRICTION - THIN JUDDER - .078" THICK	1
44	.040" THICK DRIVE PLATE - JUDDER	1
.040	.040" THICK DRIVE PLATE	7
.048	.048 THICK DRIVE PLATE	2

