

KAWASAKI ZX-10R/RR '21-

M O U N T I N G I N S T R U C T I O N S

VIDEO

REF 21782

DOWNFORCE RACE SPOILERS

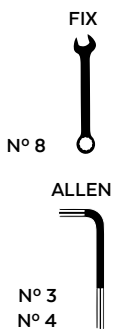

ID.	PIEZA/PART	DESCRIPCIÓN	DESCRIPTION	QTY.	REF.:
1		Pieza soporte aleron (Tamaño grande)	Spoiler support piece (Big size)	2	SOPOR-S---20431
2		Alerón derecho	Right spoiler	1	21782N/V/HM3
3		Alerón Izquierdo	Left spoiler	1	21782N/V/HM3
4		Soporte derecho (R)	Right support (R)	1	SOPOR2P8-R21782
5		Soporte Izquierdo (L)	Left support (L)	1	SOPOR2P8-L21782
6		Tuerca grafilada M5	M5 Nut	6	TUERC-D6923-255
7		Casquillo Ø8,5x Ø13x 3,5mm	Ø8,5x Ø13x 3,5mm Arrowhead	2	CASQUI-----775
8		Tornillo M5x16 Ø11 ISO7380	M5x16 Ø11 ISO7380 Allen screw	4	TORNI-I7380-493
9		Arandela de goma Ø4,5x Ø11x 2mm	Ø4,5x Ø11x 2mm Rubber washer	6	ARAND-EPDM--722
10		Tornillo M5x12 DIN7991	M5x12 DIN7991 Screw	4	TORNI-D7991-611
11		Tapón tornillo M5 DIN7991	M5 DIN7991 screw cap	4	TAPON-----92
12		Espuma adhesiva protectora (95x12mm)	Protective adhesive foam (95x12mm)	2	ESPUM-NC+ADHM--
13		Lápiz AP111 Adhesion promoter	AP111 adhesion promoter Pen	1	KITNETEJA3M----

KAWASAKI ZX-10R/RR '21-

INSTRUCCIONES DE MONTAJE - MOUNTING INSTRUCTIONS - MONTAGEANLEITUNG

1

**DISASSEMBLY
DESMONTAJE**

Se muestra el montaje del lado derecho a modo de ejemplo, realizar los mismos pasos para el montaje del lado izquierdo
The right side assembly is shown as an example, so the same steps can be performed for the left side assembly.

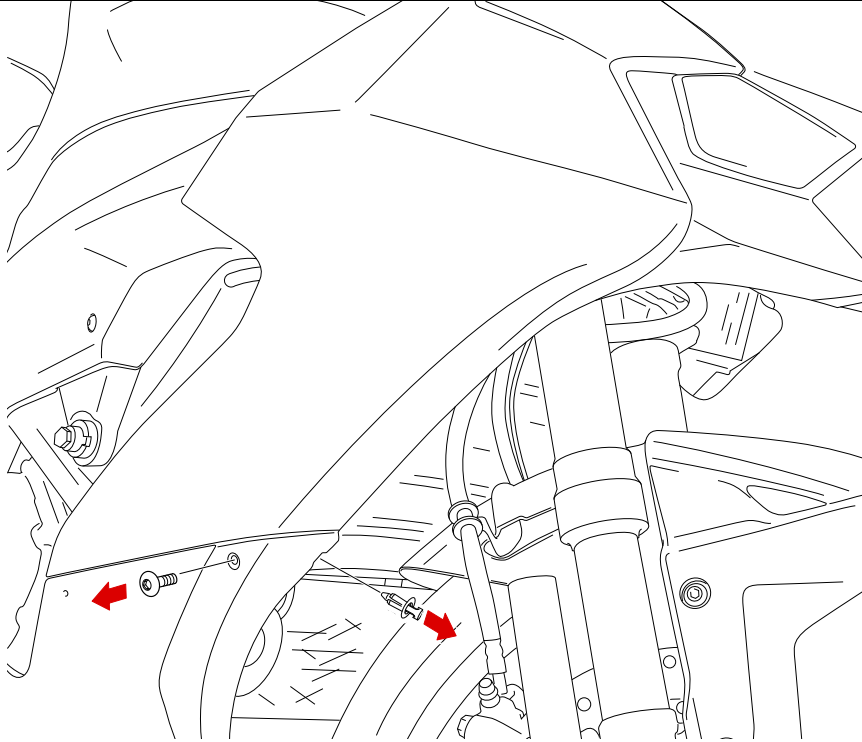

2

**ASSEMBLY
MONTAJE**

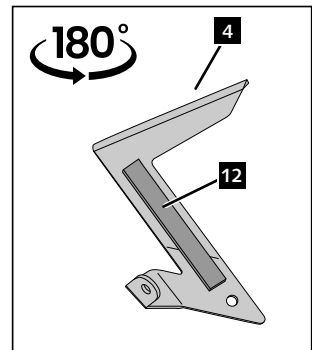
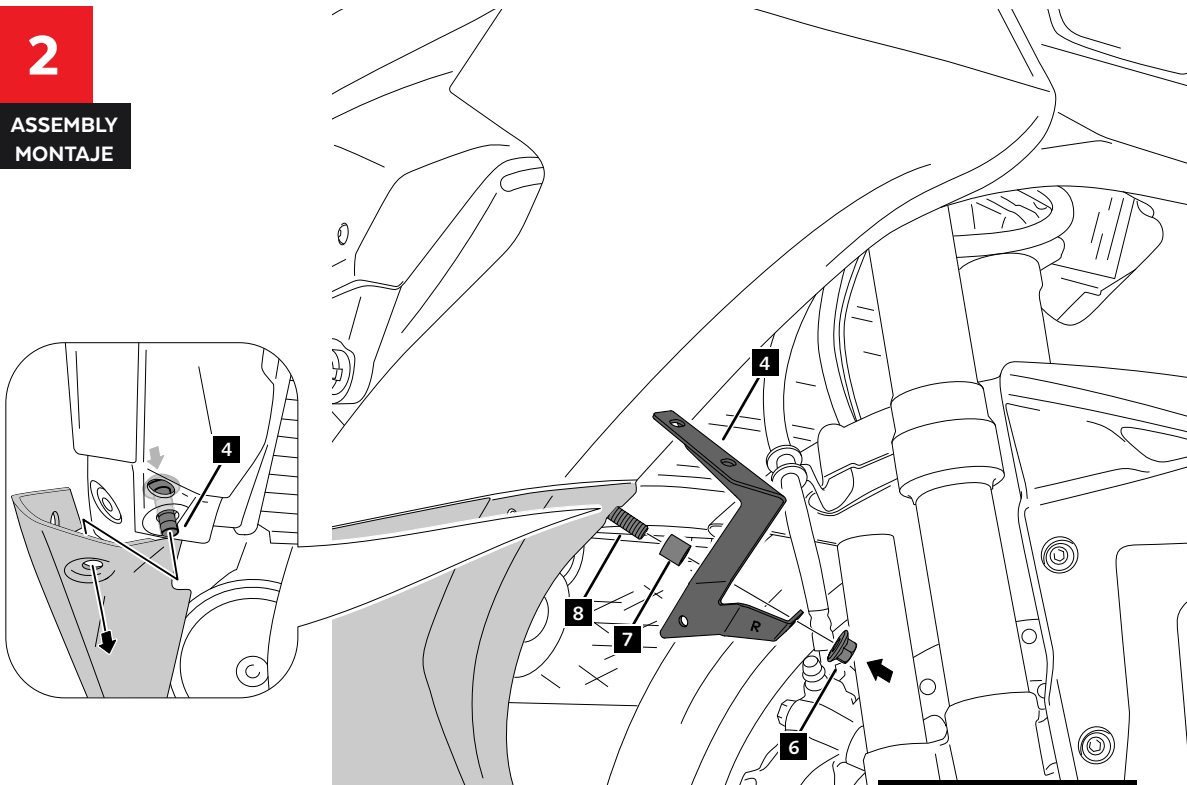

KAWASAKI ZX-10R/RR '21-

INSTRUCCIONES DE MONTAJE - MOUNTING INSTRUCTIONS - MONTAGEANLEITUNG

3

ASSEMBLY
MONTAJE

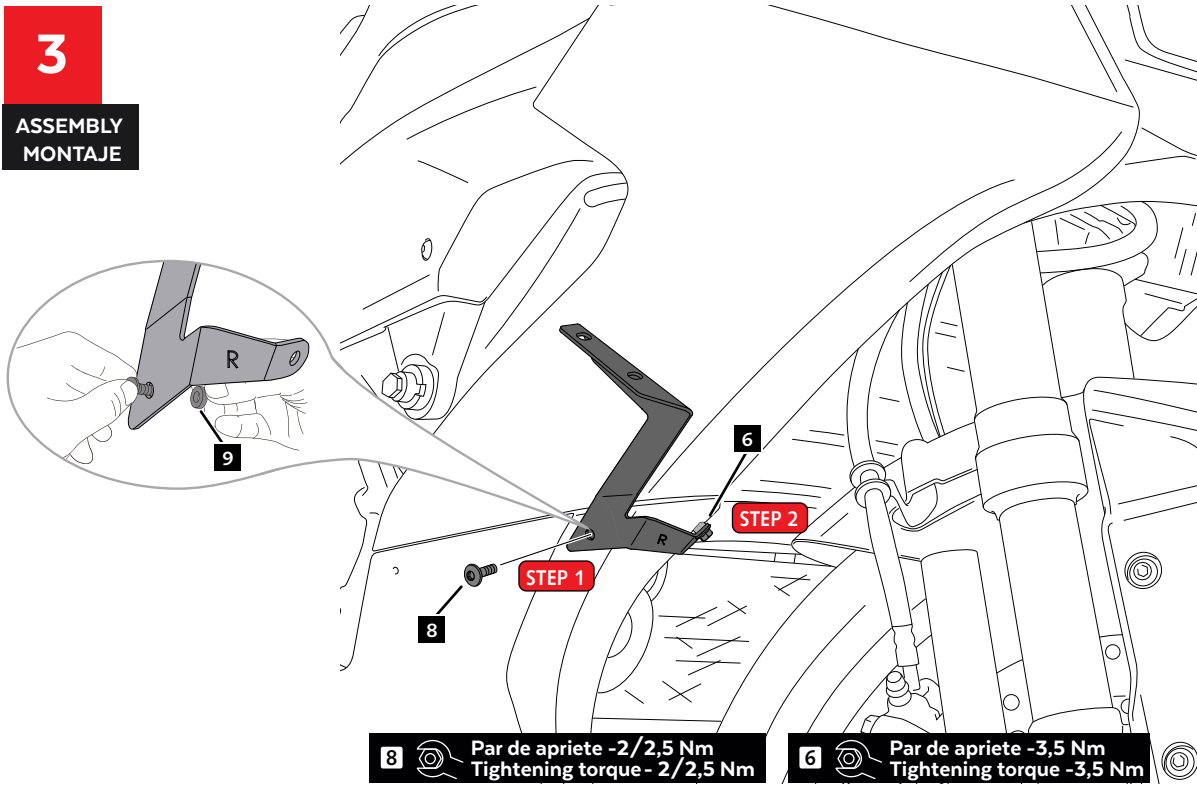

4

ASSEMBLY
MONTAJE

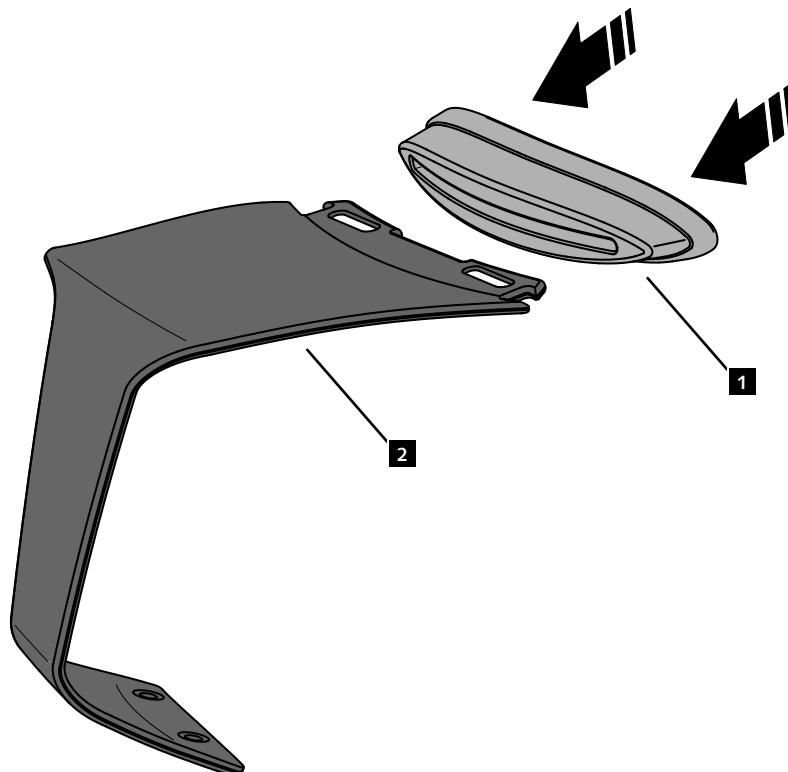

KAWASAKI ZX-10R/RR '21-

INSTRUCCIONES DE MONTAJE - MOUNTING INSTRUCTIONS - MONTAGEANLEITUNG

5

ASSEMBLY
MONTAJE

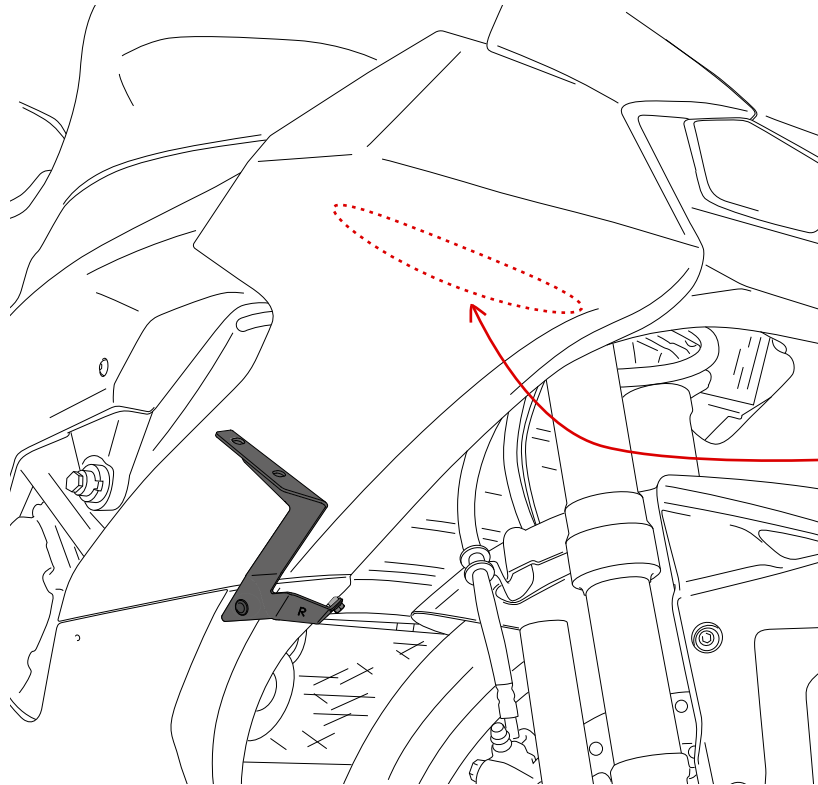

PRESS HARD THE PEN
UNTIL THE GLASS INSIDE
BREAKS AND
THE FLUID FLOWS



APPLY THE PEN
ONLY ON SPOILER
SUPPORT PIECE
AREA.



CHECK IS COMPLETELY DRY
BEFORE START.

6

ASSEMBLY
MONTAJE

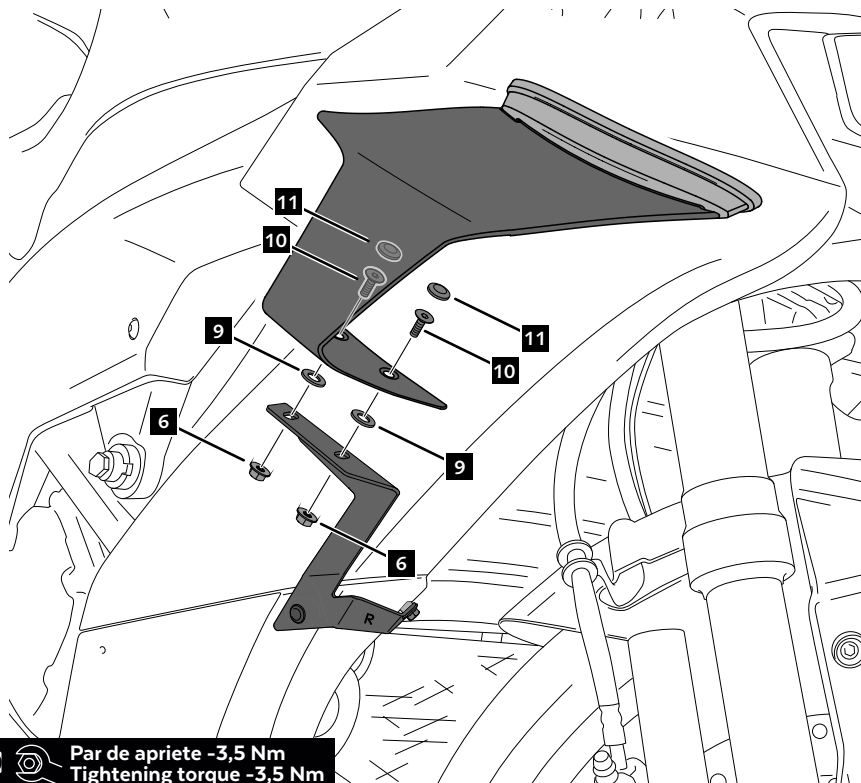

 Par de apriete -3,5 Nm
Tightening torque -3,5 Nm

KAWASAKI ZX-10R/RR '21-

INSTRUCCIONES DE MONTAJE - MOUNTING INSTRUCTIONS - MONTAGEANLEITUNG

7

ASSEMBLY
MONTAJE

7.1 DOBLAR LOS EXTREMOS DE LA PIEZA
FOLD THE ENDS OF THE PIECE

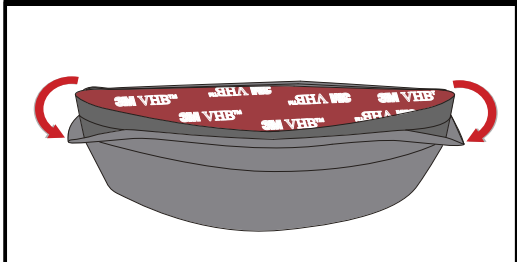

7.2 EXTRAER PAPEL DEL ADHESIVO 3M
REMOVE PAPER FROM 3M ADHESIVE

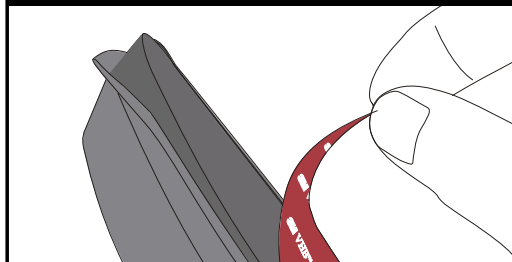

7.3

APPLY PRESSURE ON ADHESIVE AREA FOR
1 MINUT

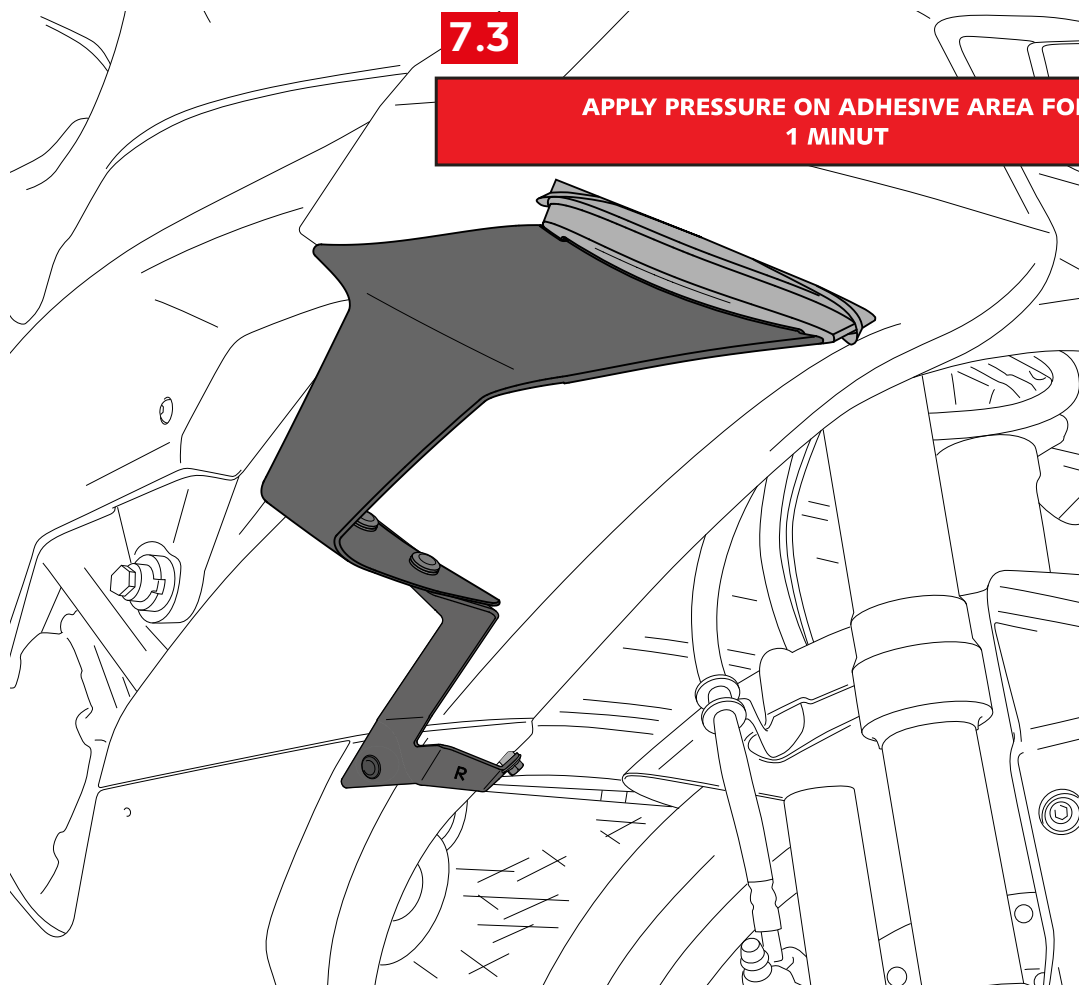

KAWASAKI ZX-10R/RR '21-

INSTRUCCIONES DE MONTAJE - MOUNTING INSTRUCTIONS - MONTAGEANLEITUNG

8

ASSEMBLY
MONTAJE

WAIT 24 HOURS



**CHECK THE CORRECT ADHESION
OF THE 3M DOUBLE SIDE
SELF-ADHESIVE TAPE
TO THE FAIRING. ENSURE THAT
THE ENTIRE SURFACE
IS WELL ADHERED**

9

ASSEMBLY
MONTAJE

**DESDOBLAR LOS EXTREMOS DE LA PIEZA
UNFOLD THE ENDS OF THE PIECE**

