



MODEL KAWASAKI Z900
KAWASAKI Z900 A2 (70KW)

LINE SLIP ON

YEAR 2017 - 2019
2017 -->

MUFFLER GP PRO

SCHEMATIC

ELENCO PARTI / PARTS LIST

#	QTÀ / QTY	DESCRIZIONE / DESCRIPTION	CODICE / CODE
1	1	Griglia / Grid	50.DK.127.0
2	1	DB killer / DB killer	50.DK.125.0
3	1	Rondella di sicurezza M5 / Safety washer M5	50.73.770.0
4	1	Vite M5 x 10 / Screw M5 x 10	50.73.858.1
5	1	Silenziatore / Muffler	GP PRO 220
6	1	Staffa / Bracket	50.SS.1018.0
7	2	Rondella di sicurezza / Safety washer	50.73.604.1
8	2	Vite M8 x 16 / Screw M8 x 16	50.73.098.1
9	1	Dado M10 flangiato / Flanged nut M10	50.73.332.1
10	1	Rondella in alluminio nera / Black aluminium washer	50.73.330.1
11	1	Vite M10x60 / Screw M10x60	50.73.135.1
12	1	Molla media / Mid-size spring	50.73.359.1
13	1	Tubo in gomma per molla / Rubber pipe for spring	50.73.210.1
14	1	Tubo di raccordo / Link pipe	9773K045S2P
15	1	Fascetta Ø 48/51 mm / Pipe clamp Ø 48/51 mm	50.FA.007.1

PARTI OPZIONALI / OPTIONAL PARTS

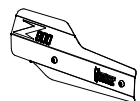

COVER IN ACCIAIO / STEEL COVER
50.CR.037.0

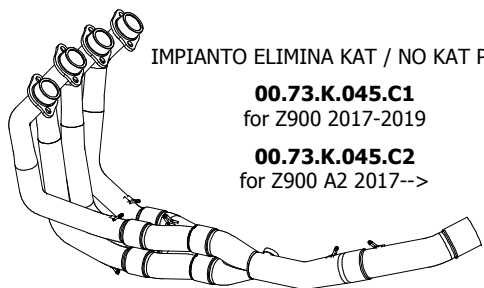

IMPIANTO ELIMINA KAT / NO KAT PIPE

00.73.K.045.C1
for Z900 2017-2019

00.73.K.045.C2
for Z900 A2 2017-->

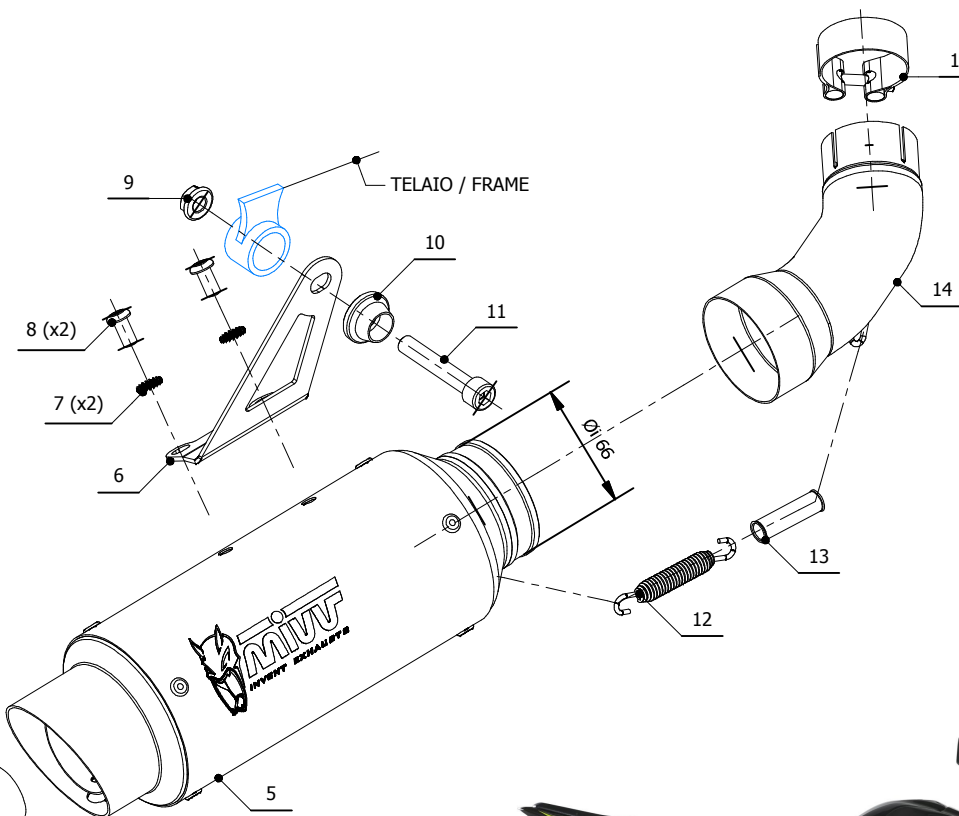
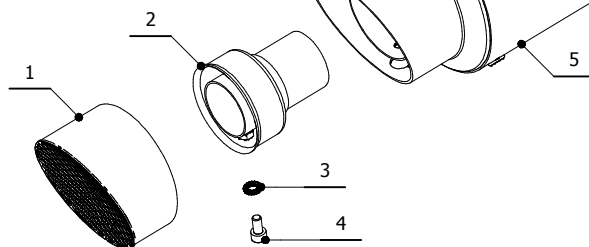

ATTENZIONE: La rimozione del riduttore di rumore è considerata una manomissione dell'impianto di scarico che comporta la perdita dell'omologazione per utilizzo stradale e della garanzia prodotto. In caso di rimozione del riduttore di rumore l'impianto di scarico è in configurazione "racing" e può essere utilizzato solo in pista.

La griglia frangifiamma può essere rimontata anche in assenza del riduttore di rumore, Tuttavia l'impianto resta in configurazione "racing" e utilizzabile esclusivamente in pista.

WARNING: Removal of the noise reducer is considered a tampering of the exhaust system which entails the loss of both the type approval for road use and the product warranty . In case of removal of the noise reducer the exhaust system is in "racing" configuration and can be only used on track.

The flame arrester can be reassembled even without the noise reducer, However, the system remains in "racing" configuration and can be only used on track.

APPLICAZIONI / APPLICATIONS

CODICE / CODE	SILENZIATORE / MUFFLER	LOGO	TUBO / PIPE
K.045.L2P	CARBONIO / CARBON FIBER	ALUMINIUM LABEL	INOX / ST. STEEL
K.045.L6P	TITANIO / TITANIUM	LASER	
K.045.LXBP	STEEL BLACK	LASER	