

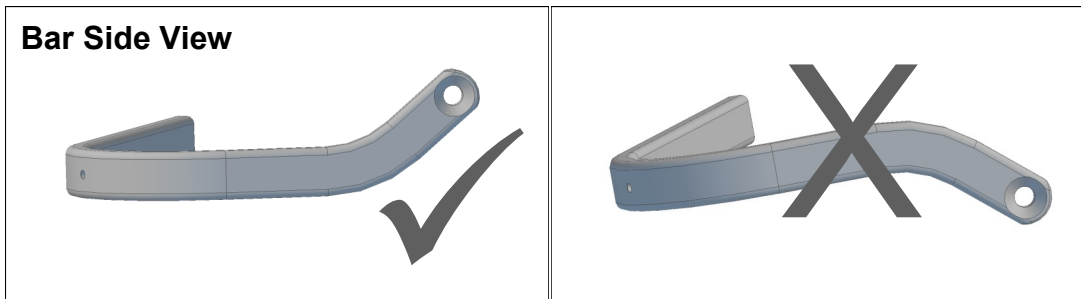

www.barkbusters.net

FITTING INSTRUCTIONS for...

- SUZUKI DL650 V-Strom
- SUZUKI DL650XT V-Strom ('15 on)
- SUZUKI DL1000 V-Strom
- SUZUKI DL1000XL V-Strom (up to '17)
- HONDA NC700X / NC750X
- HONDA XL1000V Varadero (all models)
- HONDA VFR1200X Crosstourer (non-DCT models)
- HONDA CB500X ('13 - '15)
- KAWASAKI KLZ1000 Versys (up to '14)
- URAL (all models with 22mm handlebar - '07 on)



Personalise Your Protection
Guard options sold separately

JET	JET-003
VPS	VPS-003
Storm	STM-003
CARBON	BCF-003

Important: Installation of the handguard is safety-relevant work and can be complicated. We recommend the installation be performed by a motorcycle service technician. Rideworx accepts no liability for damages caused by improper mounting.

All screws, bolts and nuts, including all replacement hardware provided by Rideworx, should be tightened to the torque specified in the table. After the first 50km of riding check all screws, bolts and nuts are tightened to the correct torque. We recommend a medium strength liquid thread lock product on all fasteners.

WARNING: Check there is clearance between the throttle grip end and the handguard to ensure a free closing throttle. Check operation of all handlebar controls, specifically the throttle, front brake, kill switch and clutch to ensure they are operating correctly and are in accordance with the OEM specifications. Do not ride the motorcycle if any controls are not operating correctly. Check periodically that all bolts are tight.



Phone: +61 (0)2 4271 8244
Email: info@barkbusters.net

1 Aluminium Bar



PN: BAR-V-030-L
Pcs. 1 Left

2 Aluminium Bar



PN: BAR-V-030-R
Pcs. 1 Right

3 Bar End Weight



PN: BEW35
Pcs. 2

4 Multi Fit Clamp 22mm



PN: MFC-22
Pcs. 2

5 Connector LEFT



PN: CP8-L
Pcs. 1

6 Connector RIGHT



PN: CP8-R
Pcs. 1

7 Socket Head Bolt 30mm



PN: M6x30SHCSZP
Pcs. 2

8 Socket Head Bolt 20mm



PN: M6x20SHCSZP
Pcs. 4

9 Button Head Bolt 25mm



PN: M8x25BHCSZP
Pcs. 2

10 Nylock Nut 6mm



PN: M6LN
Pcs. 2

11 Flat Head Bolt 75mm



PN: M8x75FHCSZPFT
Pcs. 2

12 Flat Head Bolt 45mm

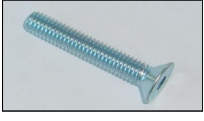

PN: M8x45FHCSZP
Pcs. 2

13 Spacer 10mm



PN: BSSRT10
Pcs. 2

14 Expander



PN: BBE17
Pcs. 2

15 Taper Nut



PN: NUT12
Pcs. 2

16 Spacer 17mm



PN: SP17-20-8
Pcs. 1

17 Washer 8mm



PN: M8FW
Pcs. 4

Recommended Torque Settings	
M6	10 Nm (7.4 lbf ft)
M8	20 Nm (17 lbf ft)



Phone: +61 (0)2 4271 8244
Email: info@barkbusters.net
Web: www.barkbusters.net



Disclaimer:

A failure to follow these fitting instructions could cause serious injury, death or property damage. These handguards are intended solely for use with motorcycles/ATV/snowmobiles/scooters that have not been modified. They are not designed to prevent injury or death while riding or in an accident or crash. The user must ensure that all controls are free of the handguards every time that they ride. By installing and/or using this product you acknowledge that you accept these terms and have followed the fitting instructions.

HONDA CB500X, NC700/750X and XL1000V Varadero Handlebar Weight Removal

Remove original handlebar end weight with internal weight parts.

Left side, roll back hand grip and depress the two retaining clips through the holes in the handlebar with a screwdriver. There is one top and one bottom. To access holes on right side, unscrew throttle housing and separate the two halves enough to slide the twist grip in from the end. Leave handlebar weight connected to the internal weight to help with removing the internal parts. Pull on weight while pressing clips through hole. See pictures to right.

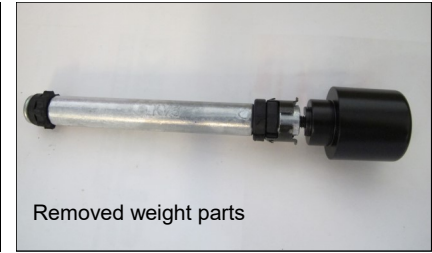
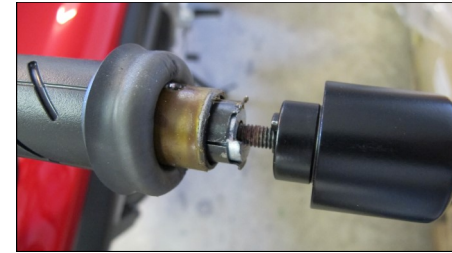
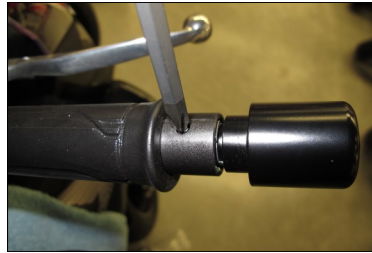

Removed weight parts

HONDA CB500X, NC700/750X & XL1000V Varadero Handguard Installation

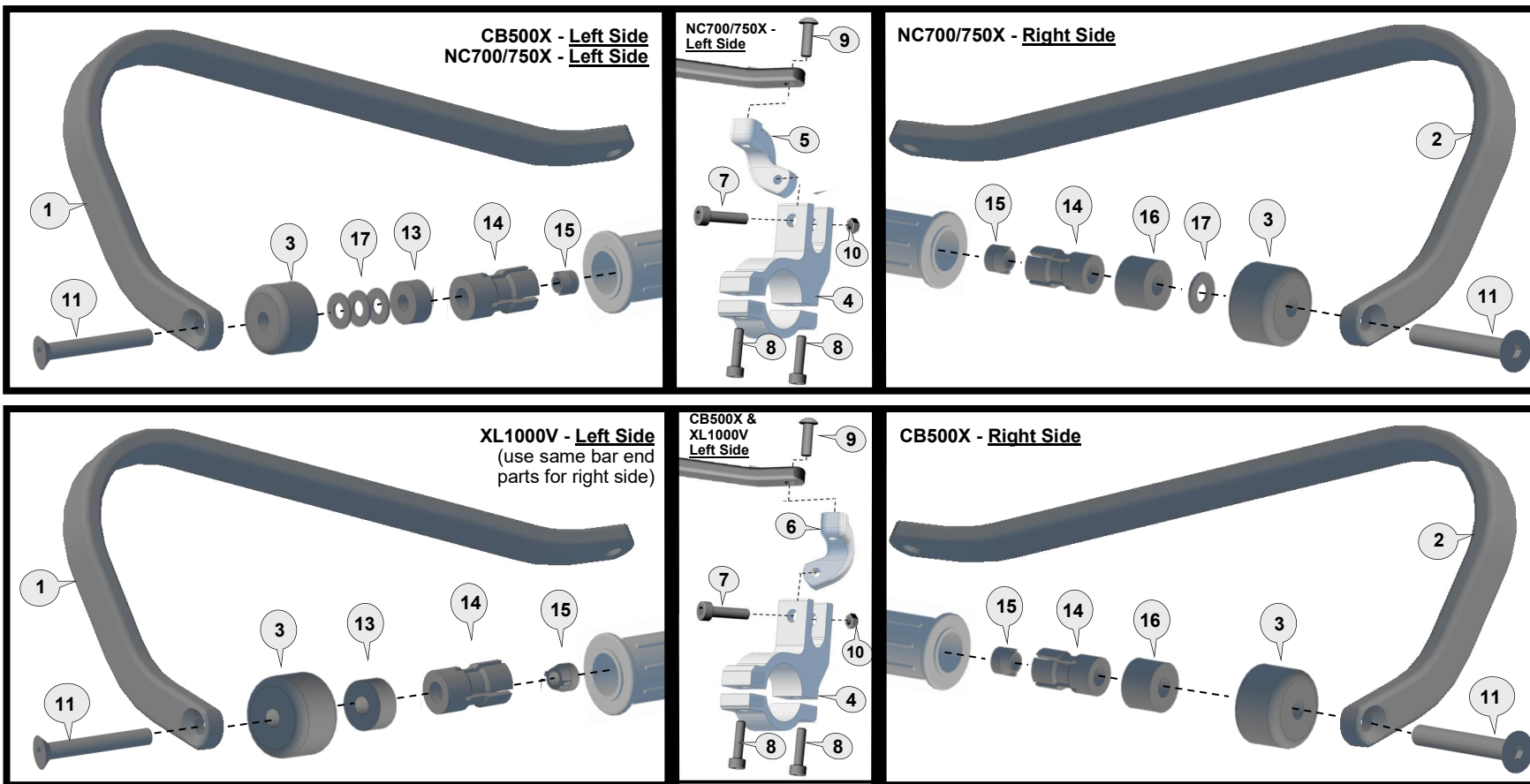

Loosely assemble the clamp to the handlebar with applicable parts (see diagram for your model bike).

Attach the handguard backbone with applicable parts to the handlebar end and also to the clamp connector (5 or 6). (see diagram for your model bike).

Position backbone so it is horizontal when viewed from the side and tighten all bolts in the following order: (11), (9), (8) then (7).

Important: Use the specified torque setting on page 2.

HONDA VFR1200X Crosstourer (non DCT) Installation

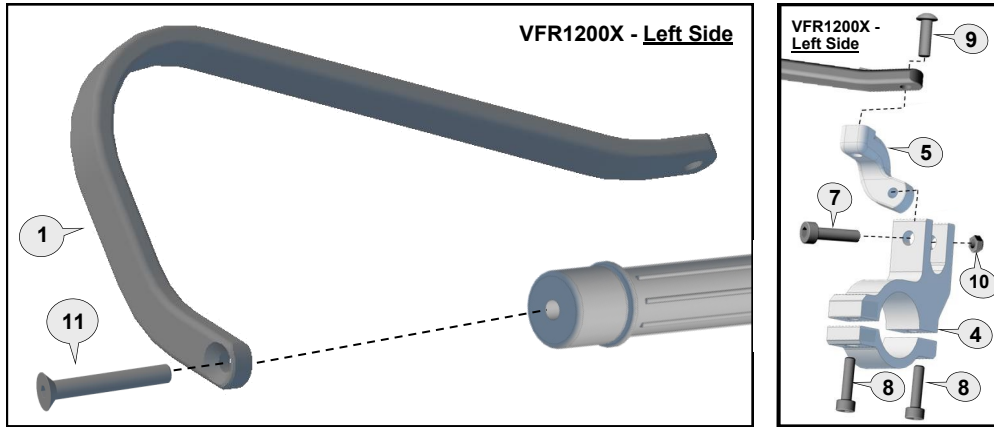

Remove original handguards and handlebar end bolts.

Installation is shown for the left side. Loosely assemble the clamp to the handlebar with clamp connector (5). Attach handguard backbone with applicable parts (with original weight/expander and internal nut) to the handlebar end and also to the clamp connector (5). Position backbone so it is horizontal when viewed from the side and tighten all bolts in the following order: (11), (9), (8) then (7). Repeat for right side with applicable parts.

Important: Use the specified torque setting on page 2.

KAWASAKI KLZ1000 Versys Installation

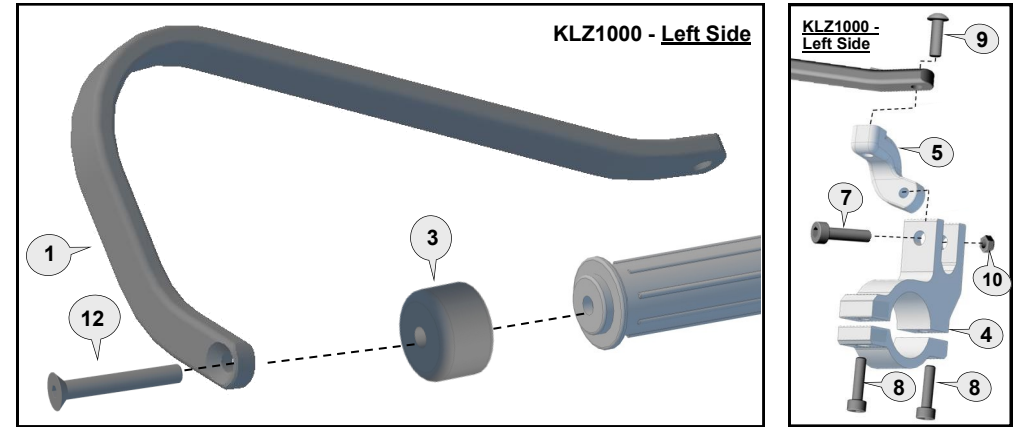

Remove original bar weights and the plastic cable guides on each side of the handlebar to allow space for clamps to be fitted.

Installation is shown for the left side. Loosely assemble the clamp to the handlebar with clamp connector (5). Attach handguard backbone with applicable parts to the handlebar end and also the clamp connector (5). Position backbone so it is horizontal when viewed from the side and tighten all bolts in the following order: (12), (9), (8) then (7). Repeat for right side with applicable parts.

Important: Use the specified torque setting on page 2.

SUZUKI DL650 & DL1000 V-Strom Installation

Remove original handlebar end weight and handguard (if installed).

Undo screw in weight about three turns, tap screw head in to free up. Pull weight out while using an up and down movement to remove the complete assembly.

Installation is shown for the left side. Loosely assemble the clamp to the handlebar with clamp connector (5). Attach the handguard backbone with applicable parts to the handlebar end and also the clamp connector (5). Position backbone so it is horizontal when viewed from the side and tighten all bolts in the following order: (11), (9), (8) then (7). Repeat for right side with applicable parts.

Important: Use the specified torque setting on front page.

Fitting Tip: Suzuki V-Strom
Check handlebar internal surface for raised ridge. (See picture) If present, align slot of expander (14) with raised ridge. Alternatively remove ridge with file or Dremel style grinder.

