



www.barkbusters.net

**FITTING INSTRUCTIONS**  
for...

- BMW R1100GS
- BMW R1150GS
- BMW R1150GSA
- YAMAHA XTZ660 Tenere ('08 on)

**Preparation**

Remove the original handguards (if fitted). For the Tenere, also remove original bar end weights.

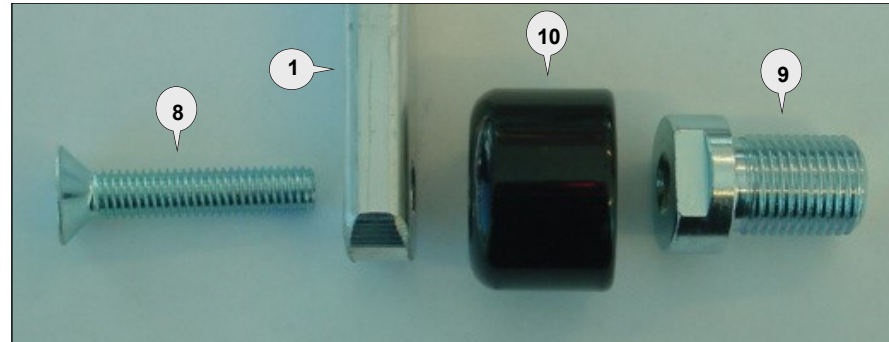
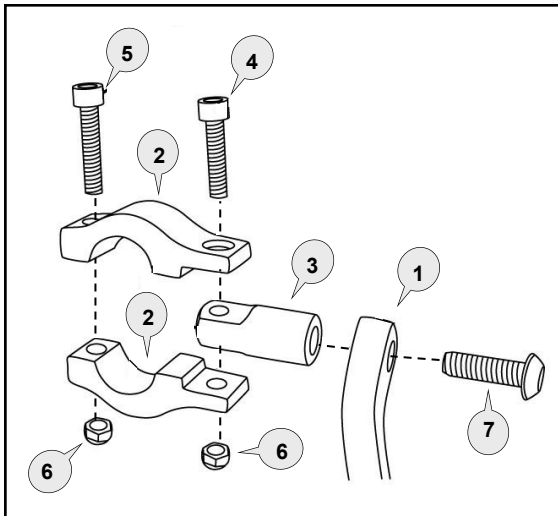

**Note:**

BMW R1100GS / R1150GS:

Items (9) and (10) are not required.  
Fit backbone (1) directly to original bar end weight with bolt (8).

YAMAHA Tenere:

When fitting to Tenere you may need to adjust the handlebar position back or forward a little to clear fairing and tank when the steering is at full lock.

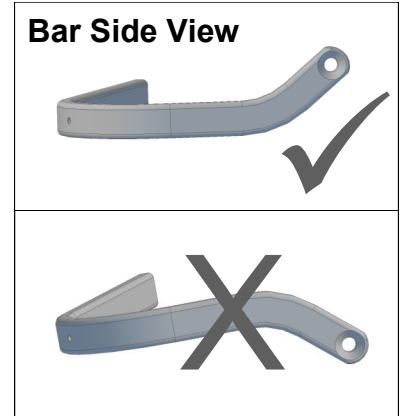

**Important Fitting Procedure**

Loosely assemble the clamp to the handlebar as per diagram. Attach the handguard with applicable parts to the handlebar end and also to the clamp connector (3).

Position backbone so it is horizontal when viewed from the side and tighten bolt (8).

**The clamp bolts must be tightened in the following order:**

**Tighten bolt (7)** through the aluminium bar (1) to the clamp connector (3) of the clamp assembly.

**Tighten bolt (4)** to solidly lock the swivel section (3) between the clamp saddles (2).

**Tighten bolt (5)** to secure the clamp assembly firmly to the handlebar.

**Note:** The clamp is designed to allow the nut on bolt (4) to pull into the recessed hole. This eliminates the need for a wrench after the bolt starts to tighten.

**Personalise Your Protection**

Guard options sold separately

**JET** JET-003

**VPS** VPS-003

**Storm** STM-003

**CARBON** BCF-003



Phone: +61 (0)2 4271 8244  
Email: info@barkbusters.net

**1** Aluminium Bar



PN: BAR-V-040  
Pcs. 1 Left & 1 Right

**2** Clamp Saddle



PN: CS-STD  
Pcs. 4 pieces

**3** Swivel 60mm



PN: CP4  
Pcs. 2

**4** Socket Head Bolt 25mm



PN: M6x25SHCSZP  
Pcs. 2

**5** Socket Head Bolt 30mm



PN: M6x30SHCSZP  
Pcs. 2

**6** Nylock Nut



PN: M6LN  
Pcs. 4

**7** Button Head Bolt 25mm



PN: M8x25BHCSZP  
Pcs. 2

**8** Flat Head Bolt 40mm



PN: M8x40FHCSZP  
Pcs. 2

**9** Bolt



PN: BESF2  
Pcs. 2

**10** Bar End Weight



PN: BEW-35  
Pcs. 2

Recommended Torque Settings	
M6	10 Nm (7.4 lbf ft)
M8	20 Nm (14.8 lbf ft)
M16 (item 9)	21Nm (15.5 lbf ft)

**CAUTION:**

Installation of the handguard is safety-relevant work and can be complicated. We recommend the installation be performed by a motorcycle service technician. Rideworx accepts no liability for damages caused by improper mounting. All screws, bolts and nuts, including all replacement hardware provided by Rideworx, should be tightened to the torque specified in the below table. After the first 50km of riding check all screws, bolts and nuts are tightened to the correct torque. We recommend a medium strength liquid thread lock product on all fasteners.

**WARNING:**

It is important there is a working clearance (approx 3mm) between the throttle grip end and the handguard to ensure a free closing throttle. Check operation of all handlebar controls, specifically the throttle, front brake, kill switch and clutch to ensure they are operating correctly and are in accordance with the OEM specifications. Do not ride the motorcycle if any controls are not operating correctly. Check periodically that all bolts are tight.



Phone: +61 (0)2 4271 8244  
Email: info@barkbusters.net  
Web: [www.barkbusters.net](http://www.barkbusters.net)



**Disclaimer:**

A failure to follow these fitting instructions could cause serious injury, death or property damage. These handguards are intended solely for use with motorcycles/ATV/snowmobiles/scooters that have not been modified. They are not designed to prevent injury or death while riding or in an accident or crash. The user must ensure that all controls are free of the handguards every time that they ride. By installing and/or using this product you acknowledge that you accept these terms and have followed the fitting instructions.