

ATV Flail Mower

ATVM120



Operator's Manual

Introduction

HSE information sheet

In the interest of safety: DO NOT

In the interest of safety: DO.....

Instruction & Warning Decals

Operating Instructions And Adjustments.....

Initial Check

Drawbar Adjustment

Mower Cutting Height

Starting The Engine

Forward Speed

Stopping The Mower

Transport Position.....

Anti-scalping roller / Side skid's.....

Maintenance Schedule

Engine

Excess Crop Build Up

Visual Check.....

Tyre Pressures.....

Rotor Bearing Inspection.....

Wheel Bearing Inspection

Oil Coupling / Bush Wear.....

General Inspection.....

Rotor Flail Maintenance

Parts List.....

INTRODUCTION

With the purchase of your FLAIL MOWER you have made an excellent choice.

This machine should give first class service for a long time, if used correctly, and maintained as described in this manual. Fitted with an easy to start engine it has been designed to cope with a wide range of conditions. The ATV — Flail mower incorporates easy height adjustment, range of engine options and a full width anti-scalping roller to avoid damage to machine and sward. The mower is constructed from 4mm steel for added strength; all fittings are of high quality to ensure years of trouble free use. Different wheel options are available for the AT Flail Mower. Engines used may vary, but all are accompanied by the maker's usual warranty.

Selecting and using equipment for all terrain Vehicles (ATVs)

Introduction

This information sheet gives advice to users on how to use all Terrain vehicles(ATVs) safely with towed and mounted equipment. Plan the use of an ATV carefully and take particular note of ground conditions and slopes, as these may vary considerably, depending on the terrain, weather conditions, ground surface and the crop under the wheels.

Towed equipment

Choose equipment which matches your ATV. Stability of towed equipment is affected by:

Weight ratios

- 1 The safe ratio between the trailed laden maximum weight and unladen weight of the ATV must be assessed for each operation.
- 2 Always take note of information given in the manufacturer's handbook when making this assessment.
- 3 As a guide research shows that on level ground, 4 x unladen weight of the ATV for braked trailed equipment and 2 x unladen weight of the ATV for unbraked trailed equipment are the appropriate maximum ratios.

Note: For work on slopes or uneven ground the ratio will need to be reduced.

Braking Fit:

- 1 Brakes to trailed equipment. This helps prevent jack-knifing when braking or traveling downhill;
- 2 Over-run brakes which come into action whenever the ATV brakes are applied;
- 3 A manually operated parking brake operable from the driving position. This provides control for use when going up slopes.

Hitching and loads

Stability is also improved if:

- 1 Some weight is transferred from the trailer onto the ATV draw-bar;
- 2 The draw-bar has a swivel hitch and the ATV a ball hitch having a large head to neck ratio. This makes it easier for the draw-bar hitch to swivel and cope with undulating ground;
- 3 The load is positioned as near to the centre of the trailer as possible.

Tyres and wheels

- 1 Check tyre pressures regularly with a pressure gauge capable of reading low pressures accurately;
- 2 Check tyres regularly for damage and wear;
- 3 Select equipment which has tyres and wheels that can cope with speeds over 20mph and occasional higher speeds;
- 4 Use wheels with bead locks on the rims if the main use is going to be on sloping ground. This prevents tyre run-off on side slopes.

Maximum towed weight

Follow the advice given by manufacturers on the maximum trailed weight. This will be found on the equipment or in the instruction handbook.

Note: Universal road going trailers will normally have the maximum gross weight stated on a separate notice.

Mounted equipment

ATVs using mounted equipment are safer if the equipment has:

- a low centre of gravity. This improves stability.
- a gross weight within the limits approved by ATV manufacturer.
- no dangerous projections to injure the operator or bystanders;
- no forward projections which stop head protection being worn;
- controls which are easy to work and which do not create a hazard to the operator;

Instructions for mounted and trailed equipment

Take note of the manufacturer's instructions on:

- operating on slopes;
- where to place loads so as to give fore/aft and lateral stability;
- the risks of using equipment with negative drawbar nose weight, ie loss of traction;
- the maximum operating speed;
- the effect that equipment carried on front and/or rear racks will have on longitudinal and lateral stability;
- securing loads;
- the use of ballast, if any, to improve stability;
- the need to select and use safe routes.

Using an ATV

- read the manufacturer's instruction book and take note of the safety advice given;
- Choose an ATV with enough power for the work you want it to do. four-wheel driver will give better traction and mobility and may provide a margin of safety;
- Choose a safe route;
- Be aware that increased speed greatly increases the risk of instability and risk of and overturn;

Training

Train everyone who has to use an ATV whether with mounted or trailed equipment or as a solo machine. The training should emphasise the factors affecting stability, the need for care and concentration, and how to recognise the conditions which may affect the safety of operation, It is important for trainees to familiarize themselves with the handling and control of the machine on level open ground before tackling rough hill terrain. Suitable training courses are run by bodies such as ATB Landbase and the forestry Authority.

Helmets

Wear head protection which protects the head and neck. Helmets are suitable. Some users find open faced helmets more suitable than full face helmets.

This symbol means WARNING or CAUTION Personal safety or damage will be at risk if these instructions are ignored. Most accidents are caused by neglect or carelessness; Avoid needless accidents by following the safety precautions listed below.

IN THE INTEREST OF SAFETY:DO NOT

- 1 DO NOT — Operate the mower without all the correct guards fitted.
- 2 DO NOT — Alter engine settings unless stated by Engine manufacturer.
- 3 DO NOT — Touch any moving or rotating parts, during working conditions
- 4 DO NOT — Stop the engine immediately after heavy use, (See section 5.6)
- 5 DO NOT — Operate the mower without suitable ear and eye protection
- 6 DO NOT — Allow passengers.
- 7 DO NOT — Leave machine un-attended while operating
- 8 DO NOT — Run the engine in an enclosed area, exhaust gases contain Carbon Monoxide and are fatal if inhaled.
- 9 DO NOT — Operate the mower on excessively steep slopes.
- 10 DO NOT — Operate the mower unless all safety features are fitted to the mower and are used correctly
- 11 DO NOT — Operate the mower until you have read and understood the entire operators manual
- 12 DO NOT — Wear loose fitting clothing, to avoid catching on parts of the machine
- 13 DO NOT — Try to remove blockages while the engine is running. Ensure engine is stopped and the rotor has finished rotating, before any servicing takes place to your mower.
- 14 DO NOT — Operate the mower in Dark conditions unless suitable artificial light is used.
- 15 DO NOT — Operate if excessive vibration occurs, stop the machine immediately and view maintenance chart.
- 16 DO NOT — Climb on the mower.

IN THE INTEREST OF SAFETY:DO

- 1 DO — Follow Engine manufactures guideline.
- 2 DO — Ensure all spectators are a safe distance away when operating.

- 3 DO— Carry out regular servicing and checks before use.
- 4 DO— Clear cutting area from potential damaging components.
- 5 DO— Reduce speeds when working on hillsides or rough terrain
- 6 DO— Be aware components can be hot after operation
- 7 DO— Follow any towing guidelines stated by ATV manufacturer.
- 8 DO — Show some caution when filling the tank with petrol, especially if engine components are hot.
- 9 DO— Ensure all safety decals are in good condition, replace any that are damaged.
- 10 DO— Keep hands and feet away from rotating blades

INSTRUCTION / WARNING DECALS

WARNING



To prevent Serious Injury or Death

- Do not operate or work on this machine without reading and understanding the operator's manual.

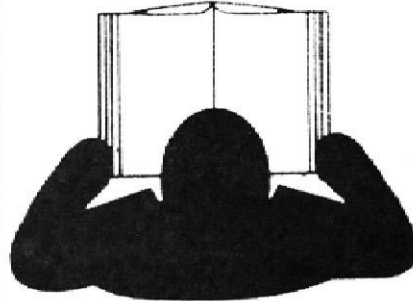

KEEP WHEEL NUTS TIGHT CHECK DAILY REFER TO THE OPERATORS MANUAL FOR CORRECT TYRE INFLATION PRESSURE OBSERVE TOWING VEHICLE MAX TOWING LIMITS OR TRAILER MAX WEIGHTS

ATTENTION

Your responsibilities before operating this machine are: • Read Understand and Follow the safety procedures manual · Train operators before using & review safety procedures regularly · Ensure that all guards are in place before operating · Keep Hand, Feet, Hair and Clothing away from all moving parts · Avoid wearing loose clothing whenever possible · Maintain as per schedule in the safety procedures. Especially Blades and Securing Hardware, due to hazard they present should any part break loose during operation · During maintenance, use suitable support stands · DO NOT allow any persons to ride on the equipment

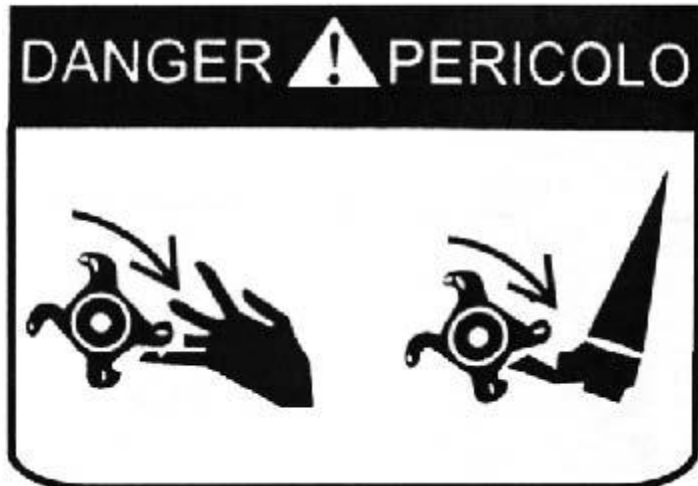
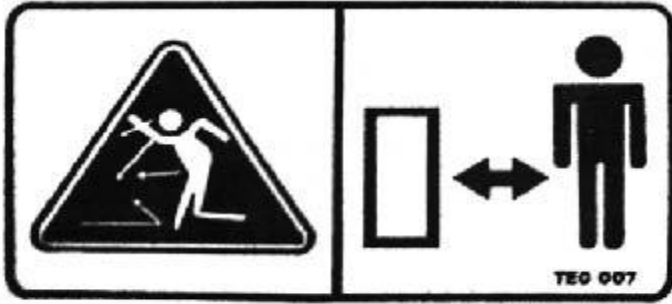

The above decals should be located on your AT – Flail Mower. If any of the above decals are not located on your AT or are damaged in any way contact for some replacement decals before use.

OPERATING INSTRUCTIONS AND ADJUSTMENTS

The AT FLAIL MOWER is designed to give safe and dependable service if operated according to instructions and intended use.

Read and understand this manual before operating the mower, as failure to do so could result in damage.

When used with an A.T.V or compact tractor, ear defenders should be worn. Under normal working conditions a noise level of 83 decibels would be usual, in the case protection is advised.

INITIAL CHECK

- 1 Make sure that all nuts, bolts and fittings are securely fixed, and that all packaging materials e.g. wire bands, tape etc have been removed. (Remove tape from the front stone deflectors from the underside of the body)
- 2 Check there is oil in the engine and petrol in the tank.
- 3 Check tyre pressures.

DRAWBAR ADJUSTMENT

The drawbar attachment height of the towing vehicle can vary. To accommodate adjustment, a screw link is located beneath the drawbar. This should be lengthened or shortened so that the cutting deck is horizontal to level ground. (This ensures a better cutting efficiency)

TO ADJUST

- 1 Unlock the locking nut (A)
- 2 Lengthen the link to lower the front of the deck or shorten to raise the deck.
- 3 Once the deck is level, re-tighten locking nut (A).

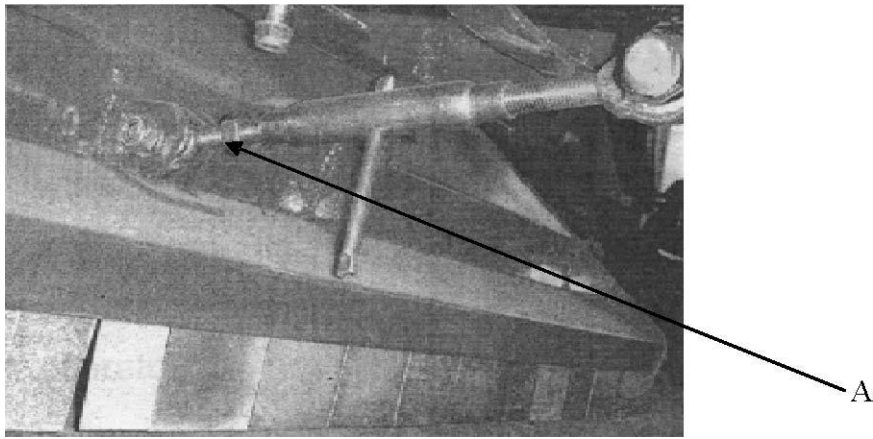

QUICK OFFSET DRAWBAR Unlock the nut and screw slide the drawbar to the desired position and release the screw into the securing hole then lock the nut, as shown.

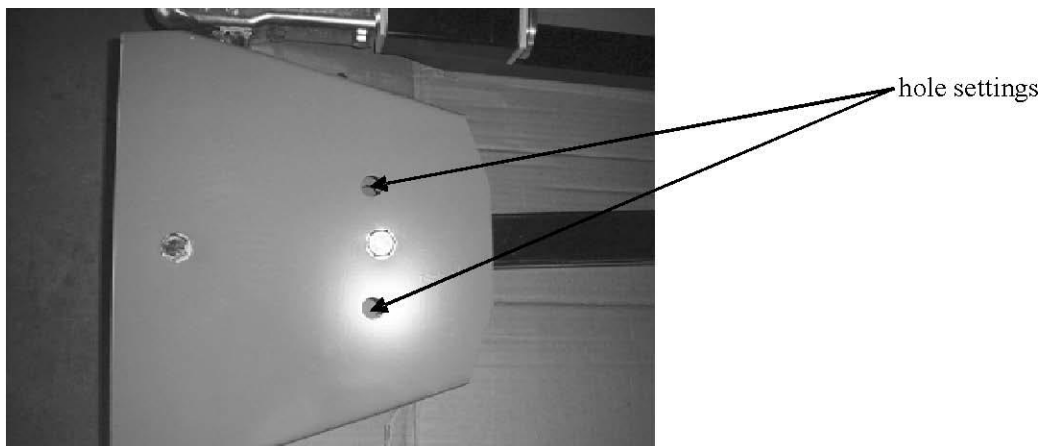

MOWER CUTTING HEIGHT

The main cutting height adjustment is achieved by using the screw jack, to raise or lower the cutting deck as necessary.

CUTTING HEIGHT ADJUSTMENT:

Turn the handle to raise or lower as necessary.



STARTING THE ENGINE

READ AND UNDERSTAND THE ENGINE OPERATOR'S MANUAL

Observe all safety precautions; keep hands and feet away from rotor and other moving parts. Keep spectators at a safe distance.

- 1 Make sure there is a gap between the blades and the ground / crop
- 2 Select an area clear of loose debris that could be picked up.
- 3 Set the engine choke, and suitable idling speed with the throttle.
- 4 Place one foot on top of the deck body to give a firm and balanced position. Pull the starter cord firmly, allowing the cord to return to return to the housing slowly (one or two strong pulls should start the engine).
- 5 After a few seconds warming up at idling speed, move the throttle to the factory pre-set position.

NOTE If the throttle is altered to increase the engine R.P.M beyond the recommended level, the guarantee may become invalid. In addition to this, cutting efficiency will be reduced, fuel consumption will increase and excessive vibration could be caused, resulting in a potential danger to personnel and damage to components.

ELECTRIC START Push button electric start engine options can be supplied if required. Simply hitch up the mower, connect the electrical supply plug to the ATV socket and turn the ignition key to start the mower. Observing all the precautions mentioned above in 'Starting

REMOTE THROTTLE CONTROL When a remote throttle control option is fitted, normally to the rear carrier frame of an ATV or other suitable site on the towing vehicle, it gives the operator the facility of controlling the mower engine from the operating position.

The facility is most beneficial when moving from one cutting site to another close to it, by reducing the engine revs to allow the mower flails to come to rest, no harm will be caused to the mower or ground surface during transport, often over rough or difficult terrain when stones and loose objects may be encountered.

FORWARD SPEED

The amount of grass or weeds to be cut dictates the forward speed; slow forward speeds give better results in most cases. Ensure you follow the procedure below. **NORMAL FORWARD**

SPEED (1 kph – very heavy use – 10 kph – very light use)

Start off in the slowest speed possible, ensure the mower is working efficiently with the engine set at maximum RPM and not labouring. (If this is not possible due to very heavy cutting conditions, raise cutting height of blades and be prepared to go over twice with machine set lower on 2nd pass, leave at least 24 hours in between 1st and 2nd cut to allow grass to dry out) Increase forward speed until the RPM of the engine starts to slow down (This is working the engine too hard for conditions) – slow down, let the engine regain full RPM and go through the same process but stop short of speed which made engine labour previously. It is important always to listen to note of engine to ensure engine and mower are working efficiently, slow down or stop once engine starts to labour.

FAILURE TO DO THIS WILL RESULT IN CLUTCH SLIP AND ULTIMATELY SEVERE DAMAGE TO THE CLUTCH AND DRIVE

When moving from normal working conditions to heavier cutting, it may be evident that the engine dies down and loses revs. SLOW DOWN IMMEDIATELY to allow the engine revs to build up again to normal working speed. Follow the procedure detailed above in “Normal Forward Speed”. Expected forward speed will be much lower in heavy conditions.

FAILURE TO DO THIS WILL RESULT IN CLUTCH SLIP AND ULTIMATELY SEVERE DAMAGE TO THE CLUTCH AND DRIVE BELTS.

STOPPING THE MOWER

When stopping the mower after a period of heavy use. Run the machine at half working speed in a stationary position, for at least 4 minutes, to allow the drive belts to cool down.

- 1 Show caution to hot parts e.g. engine exhaust, belts etc after engine is switched off.
- 2 Ensure the mower drawbar has been adjusted to allow the mower to run directly behind the towing vehicle and is not in an offset position
- 3 When the mower has cooled down (Min 1hr after last used) Ensure all grass has been removed from engine cooling fins, drive belt area, and rotors before operating again.

TRANSPORT POSITION

When the mower is being moved from one site to another it is advisable to raise the deck to the highest position (Transport position, See section 5.3 “Mower cutting height”)

The engine must be stopped and the blades at a standstill before adjusting to the transport position.

Remove any crop debris from the deck before leaving the field.

Never move from one site to another with the engine running.

Please note the AT – Flail Mower is not road legal, and should not be used on public roadways

ANTI-SCALPING ROLLER/SIDE SKIDS

The main purpose of the anti scalping roller is to prevent damage. If a wheel drops into a hole, or there is uneven ground between the wheels, the roller takes the weight of the mower, avoiding the flails scalping the ground; combined with the side skids the mower provides good protection to the rotor. The anti scalping roller has the added advantage of enabling kerb side grass to be cut with no difficulty, by allowing the wheel to hang over the kerb edge. The factor pre-set position of the anti scalping roller and side skids are suitable for most situations. However, if the mower is used in rough conditions or regularly in heavy crops, the roller and side skids should be lowered, to increase the clearance between the flail and the ground when the roller comes into use. In circumstances where the mower is being used as a “Finishing Mower” and a striped appearance is desired, the roller can be set down using the various hole positions give the

TO ADJUST THE ROLLER: Slacken pivot bolt “A”. Slacken and remove bolt “B” (Repeat for both ends of the roller) Select another hole and Replace bolt “B”. Tighten bolts “A” and “B”

TO ADJUST THE SIDE SKIDS: Remove the bolt at the Front of the skid and the rear of the skid (show as “C”)

Select new setting, replace the bolts and tighten. Repeat for the opposite skid; always ensure both skids are set to

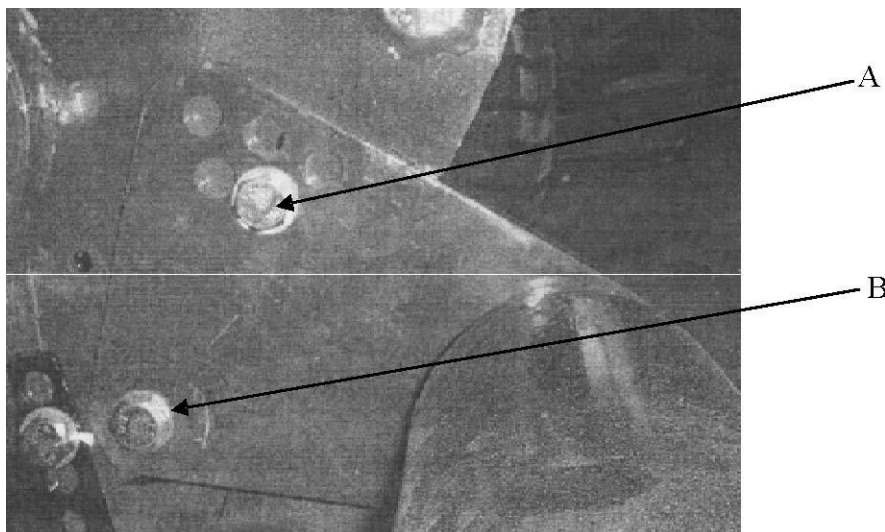

MAINTENANCE SCHEDULE

Maintenance Schedule				
Maintenance Operation:	Hourly	Daily	Weekly	Seasonal
Engine (See Engine manufacturers manual)	•	•	•	•
Remove excess crop gathered on deck	•	•	•	•
Remove excess crop wrapped around rotor ends	•	•	•	•
Visual check to ensure nothings loose		•	•	•
Grease Height Adjuster		•	•	•
Grease Rear Roller		•	•	•
Grease Rotor Bearings		•	•	•
Tyre Pressures			•	•
Drive belt inspection			•	•
Rotor Bearing inspection			•	•
Wheel bearing inspection			•	•
Oil 50mm coupling			•	•
Swivel hitch Bush Wear			•	•
Check All Fastener's are tight and intact			•	•
Safety Chain Guard inspection			•	•
Safety Decals intact			•	•
Safety Guards Intact			•	•
Check Blade wear / condition				•
Check Metal Fatigue				•
Clutch Wear / Function				•

ENGINE

Refer to engine manufacturers manual, for servicing and maintenance of the engine.

EXCESS CROP BUILD UP

Remove all crop deposits from the deck, and engine area. Build up of crop deposits could result in heat build and fires Disconnect the spark plug lead. Remove any crop that is wrapped around the

end of the rotor (A) or on the underside of the deck. Raise the deck to its max height to assist access to the rotor shaft.

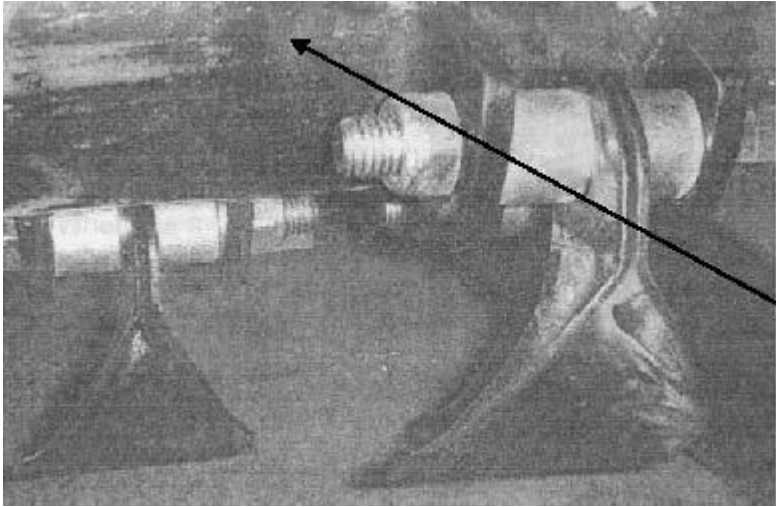

A

VISUAL CHECK

Make a visual check around the mower, check for missing / loose parts or damaged / worn components. All-faults must be either repaired or replaced.

TYRE PRESSURES

DO NOT exceed recommended type pressures

22×1100	-8	7 – 10 PSI
16.5×6.50	-8	28 PSI (Max)

ROTOR BEARING INSPECTION

Rotate rotor shaft by hand and feel for any roughness in the bearings. Also try to pull the shaft from side to side to see if any movement is found. If symptoms persist str down the rotor-housing unit and inspect bearings.

WHEEL BEARING INSPECTION

Jack one side of the mower body up, so the wheel is just off the ground. Rotate the wheel by hand,

and check the wheel alignment. To check the bearing, try to move the wheel from left to right and feel for any play in the bearings (A), ensure the wheel-locating bolt is tight before you start and follow any jacking procedures. If any play is found remove the wheel and inspect bearings. Replace any faulty bearings.

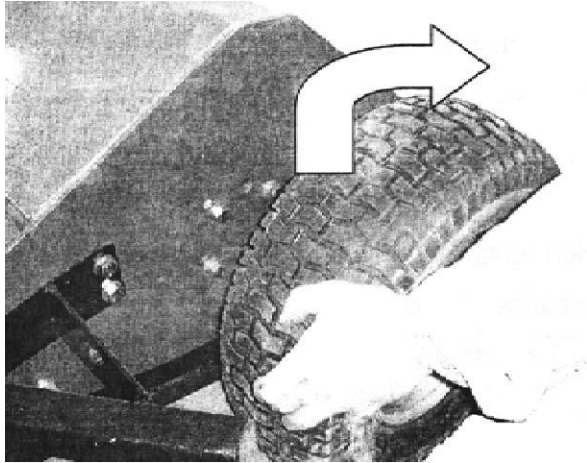

OIL 50mm COUPLING/BUSH WEAR

Check coupling for signs of damage or wear, swivel the coupling 36. degrees and check that the bushes are not too worn. Replace any worn or damaged parts.

Oil the coupling regularly as shown below.

GENERAL INSPECTION

Check the mower to ensure all fasteners are tight and all safety guards / chains are intact and fitted securely. Check all safety-warning decals, Replace any defective guards or damaged decals.

ROTOR FLAIL MAINTENANCE

However, when breaking or losing a knife, it is important to replace it immediately. Failure to do this can cause serious unbalancing problems. (Always use spare parts) At the time of replacement, the opposite knife on the rotor should be checked for wear. If it is partially or well worn then it should be changed to maintain an accurate weight balance. When the first cutting edge is becoming blunt, the whole set of flails should be turned around.

(Using blunt knives will reduce the cutting efficiency and increase fuel consumption).

Replacing or reversing the knives follows this simple procedure:

(A) Ensure mower engine has stopped and the knives have stopped rotating. Switch off the fuel tap and let the machine cool down for 5 minutes. Remove the spark plug to ensure the engine cannot be started.

(B) Raise the mower to its max cutting height.

(C) Carefully raise the drawbar to an incline position, so that height adjuster bar at the rear of the mower takes the weight. NB; Do not attempt this with the wheels behind version; raise the front jack to its max height.

(D) Slacken and take out the shackle bolt.

(E) Replace or turn around blades (Note the direction of rotation)

(F) Replace shackle bolt securely, but still allowing the shackle to swing on the fixing bush.

NOTE:

Never use cracked or repaired shackles when replacing knives. If the shackle fixing has
For repairs beyond the minor adjustments listed above, contact your local dealer or contact.

ATV Flail Mower Part List

ATV Flail Mower Assembly

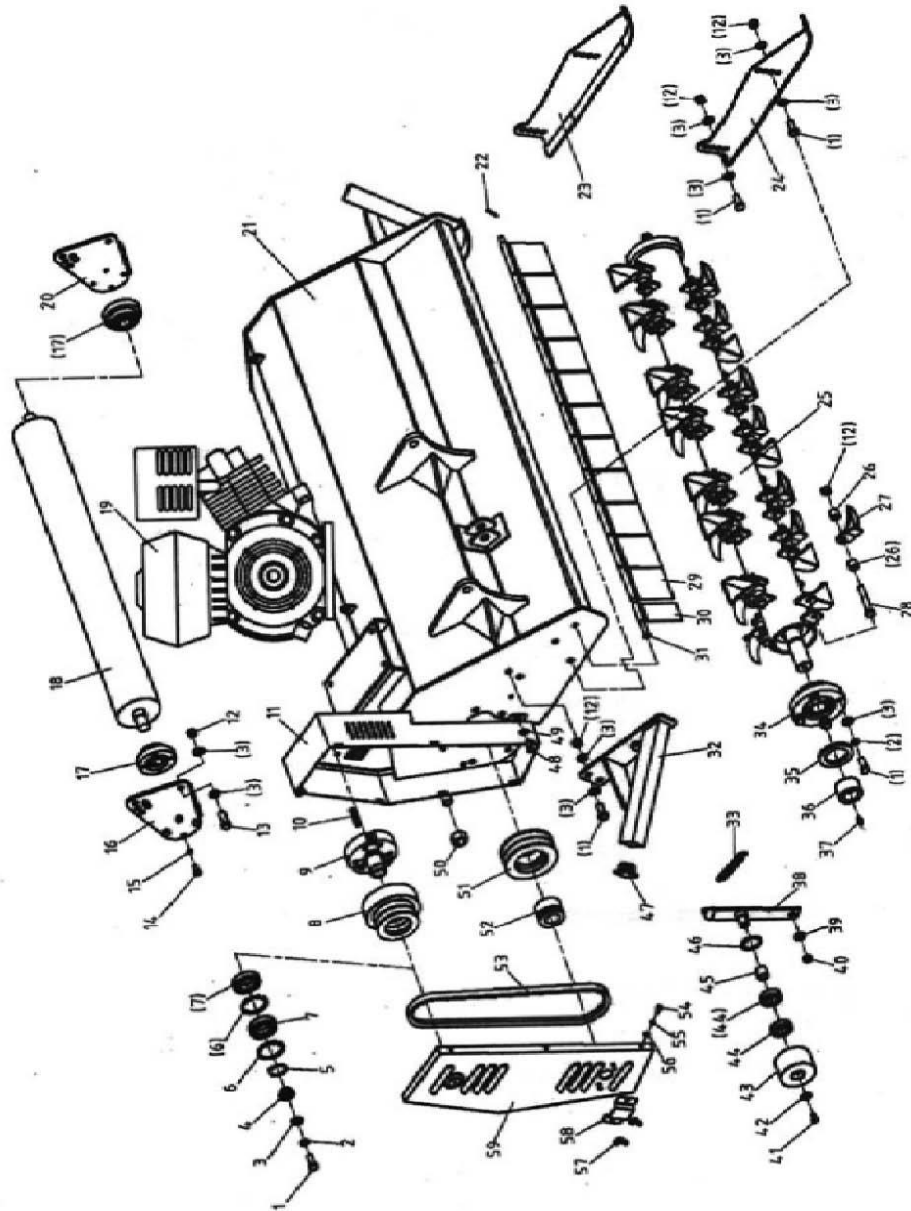

ATV Flail Mower Assembly

NO.	Part NO.	Name & Specifications	Quantity	Remark
1	GB5783-86	Blot M12x30	19	
2	GB93-87	Spring washer 12	9	
3	GB97.1-85	Plain washer 12	37	
4	MFP120.00.106	Fixing sleeve	1	
5	GB894.1-85	Circlip 35	1	
6	GB893.1-86	Circlip 62	2	
7	GB278-89	Bearing 6007Z	2	
8	MFP120.00.152	Driving	1	
9	MFP120.00.017	Belt wheel	1	
10	GB1096-79	Clutch Key 6.3x7x50	1	
11	MFP120.00.018	Protecting for transmission	1	
12	GB6184-86	Locking nut M12	42	
13	GB5783-86	Blot M12x35	4	
14	GB5783-86	Blot M8x20	8	
15	GB93-87	Spring washer 8	8	
16	MFP120.00.155	Supporting plate (R)	1	
17	EF100.00.012	Bearing UC205	2	
18	RK120.017	Roller weldment	1	
19	JF390	Gasoline engine	1	
20	MFP120.00.156	Supporting plate (L)	1	
21	MFP120.00.012	Deck weldment	1	
22	GB91-86	Split pin 4x28	1	
23	MFP120.00.026	Adjusting plate (R)	1	
24	MFP120.00.025	Adjusting plate (L)	1	
25	RK120.020	Blade axle	1	

ATV Fiall Mower Assembly

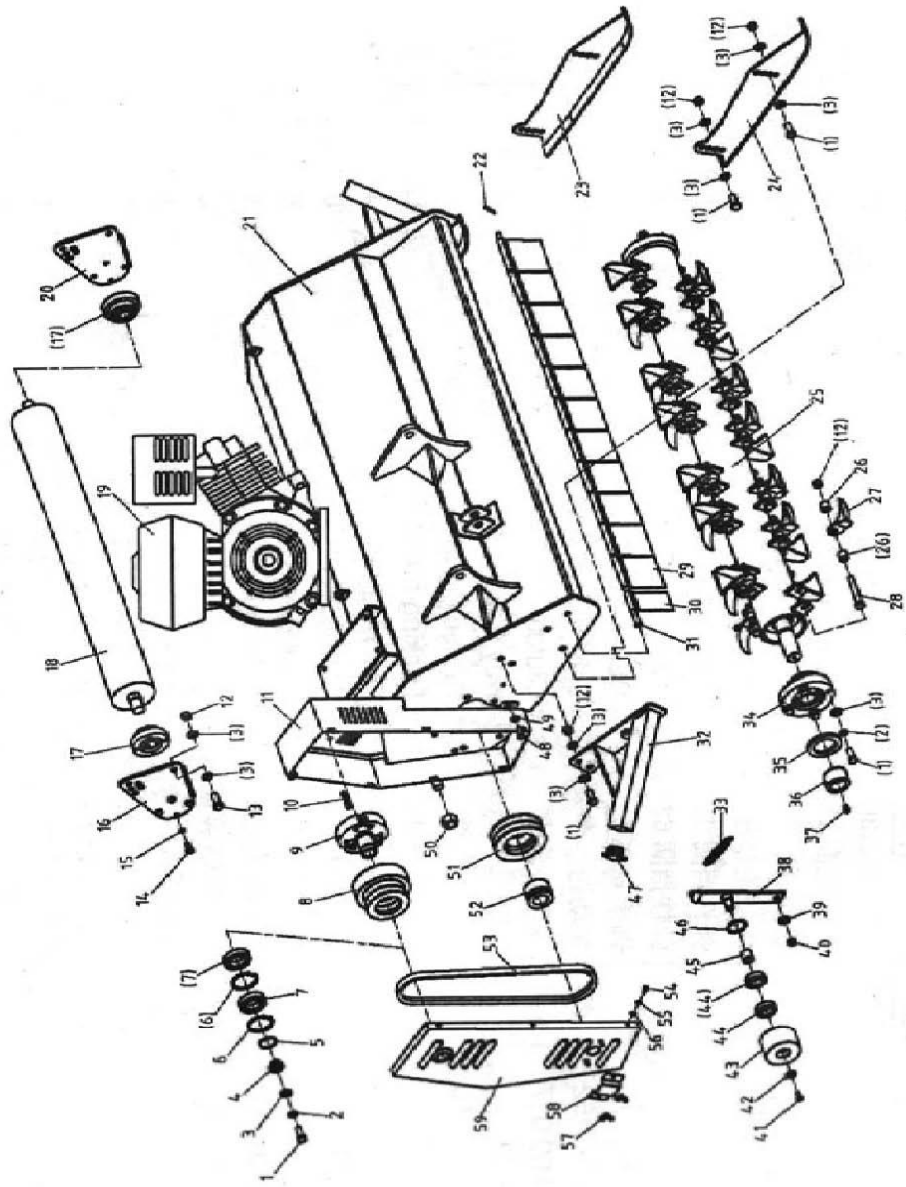

ATV Flail Mower Assembly

NO.	Part NO.	Name & Specifications	Quantity	Remark
26	EF100.00.101	Sleeve	56	
27	RK120.114a	Blade	28	
28	GB5782-86	Blot M12x80	28	
29	EF100.00.122	Baffle	12	
30	EF100.00.121	Baffle	1	
31	MFP120.00.109	Shaft	1	
32	MFP120.00.024	Protecting bracket	2	
33	MFP120.00.116	Tension spring	1	
34	UC207-Z	Bearing seat 90207	2	
35	GB13871-94	Oil seal FB55x80x8	2	
36	RK120.109	Oil-sealing sleeve	2	
37	GB1152-89	Oil cup M8x1	1	
38	MFP120.00.036	Bracket for tension spring	1	
39	GB97.1-85	Plain washer 10	1	
40	GB6184-86	Locking nut M10	1	
41	GB5783-86	Blot M8x16	1	
42	GB96-85	Plain washer 8	1	
43	MFP120.00.153	Tensioner	1	
44	GB279-88	Bearing 180105	2	
45	MFP120.00.154	Sleeve	1	
46	GB893.1-86	Circlip 47	1	
47	MFP120.00.101	Cover	2	
48	GB5783-86	Blot M8x25	2	
49	GB97.1-85	Plain washer 8	2	
50	GB6184-86	Locking nut M20	2	

ATV Flail Mower Assembly

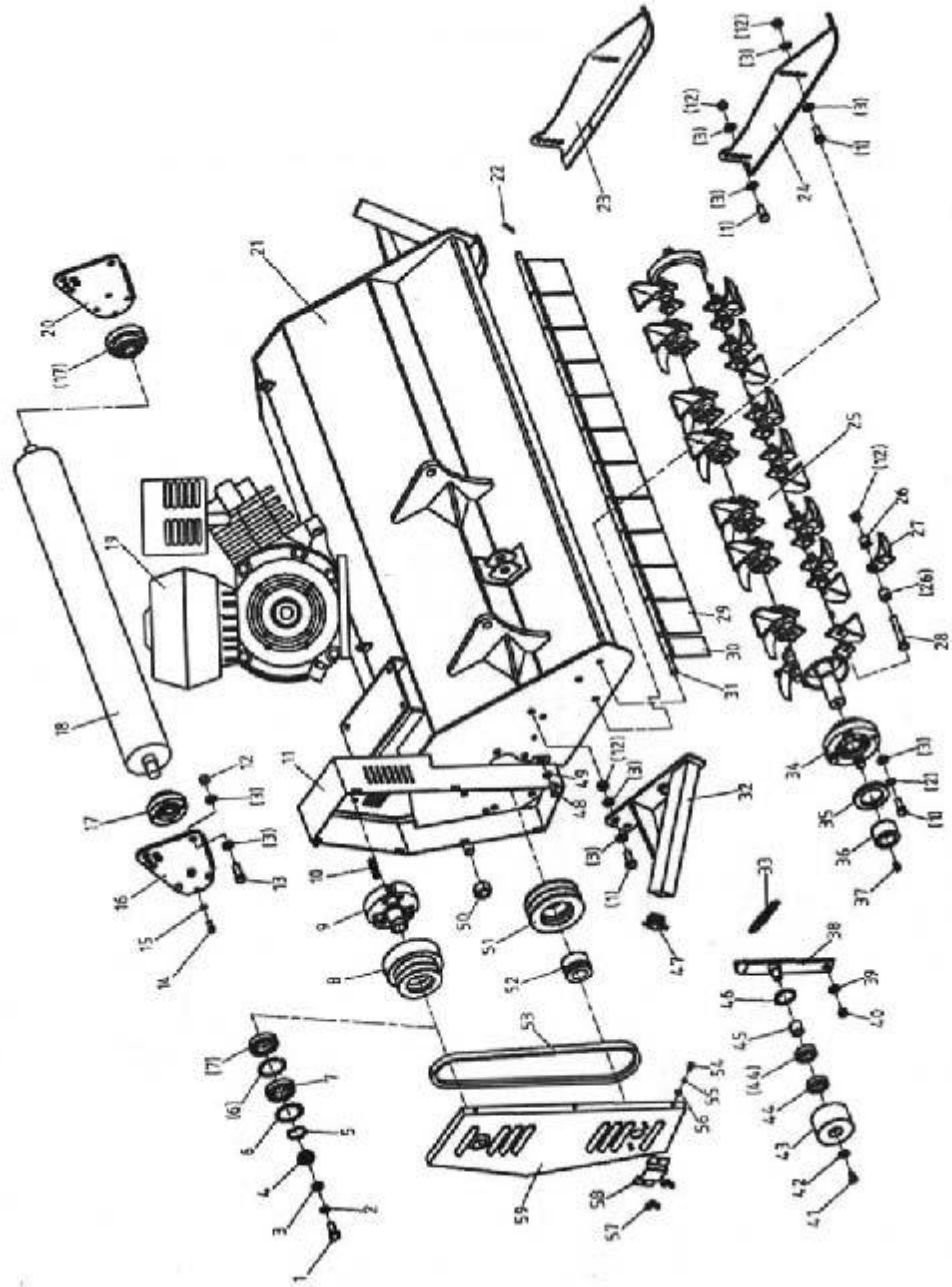

ATV Flail Mower Assembly

NO.	Part NO.	Name & Specifications	Quantity	Remark
51	MFP120.00.107	Driven belt wheel	1	
52	JB/T7934Z3	Swellable sleeve	1	
53	GB12732	Belt 1067	2	
54	GB5783-86	Bolt M6x16	7	
55	GB93-87	Spring washer 6	7	
56	GB97.1-85	Plain washer 6	7	
57	GB62-88	Butterfly nut M6	2	
58	MFP120.00.111	Cover plate	1	
59	MFP120.00.011	Protecting cover	1	

Wheel Partment Assembly

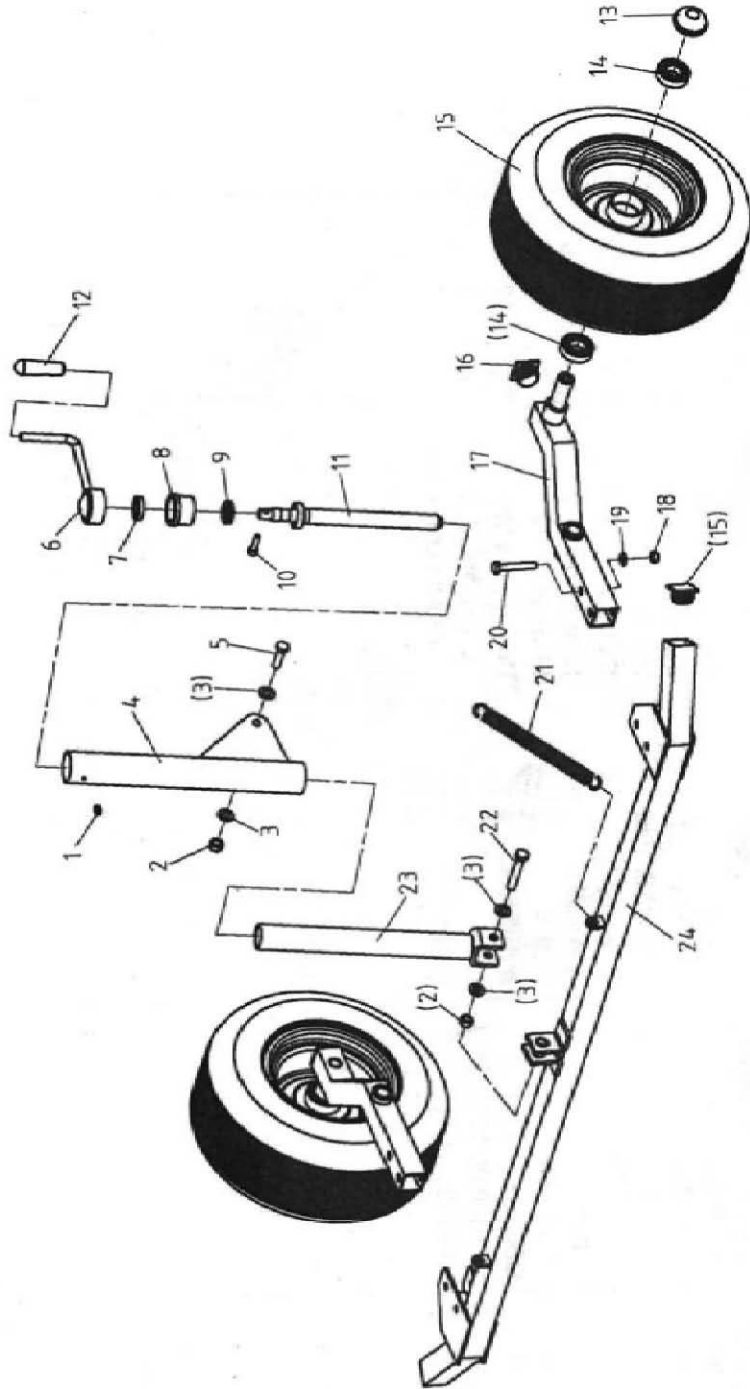

Wheel Partment Assembly

NO.	Part NO.	Name & Specifications	Quantity	Remark
1	GB1152-89	Oil cup M6	1	
2	GB6170-86	Mut N12	2	
3	GB97.1-85	Plain washer 12	4	
4	MFP120.00.038-A	Protection casing weldment	1	
5	GB5783-86	Bolt M12x35	1	
6	MFP120.00.039	Handle	1	
7	GB276-94	Bearing 61904	1	
8	TR200.00.123	Bearing seat	1	
9	GB301-95	Bearing 51104	1	
10	GB70-85	Screw M8x30	1	
11	TR200.00.120	Adjusting screw	1	
12	MFP120.00.176	Sheath for handle	1	
13	MFP120.00.148	Cover for tyre	2	
14	GBT278-94	Bearing 80205	4	
15	MFP120.00.016	Tyre	2	
16	MFP120.00.101	Rubber cover	4	
17	MFP120.00.027	Supporting bracket for tyre	2	
18	GB889-86	Nut M10	4	
19	GB97.1-85	Plain washer 10	4	
20	GB5782-86	Blot M10x65	4	
21	MFP120.00.115	Tension spring	2	
22	GB5782-86	Bolt M12x70	1	
23	MFP120.00.037-A	Adjusting coil	1	
24	ATV120.028	Crossbeam weldment	1	

Traction Assembly

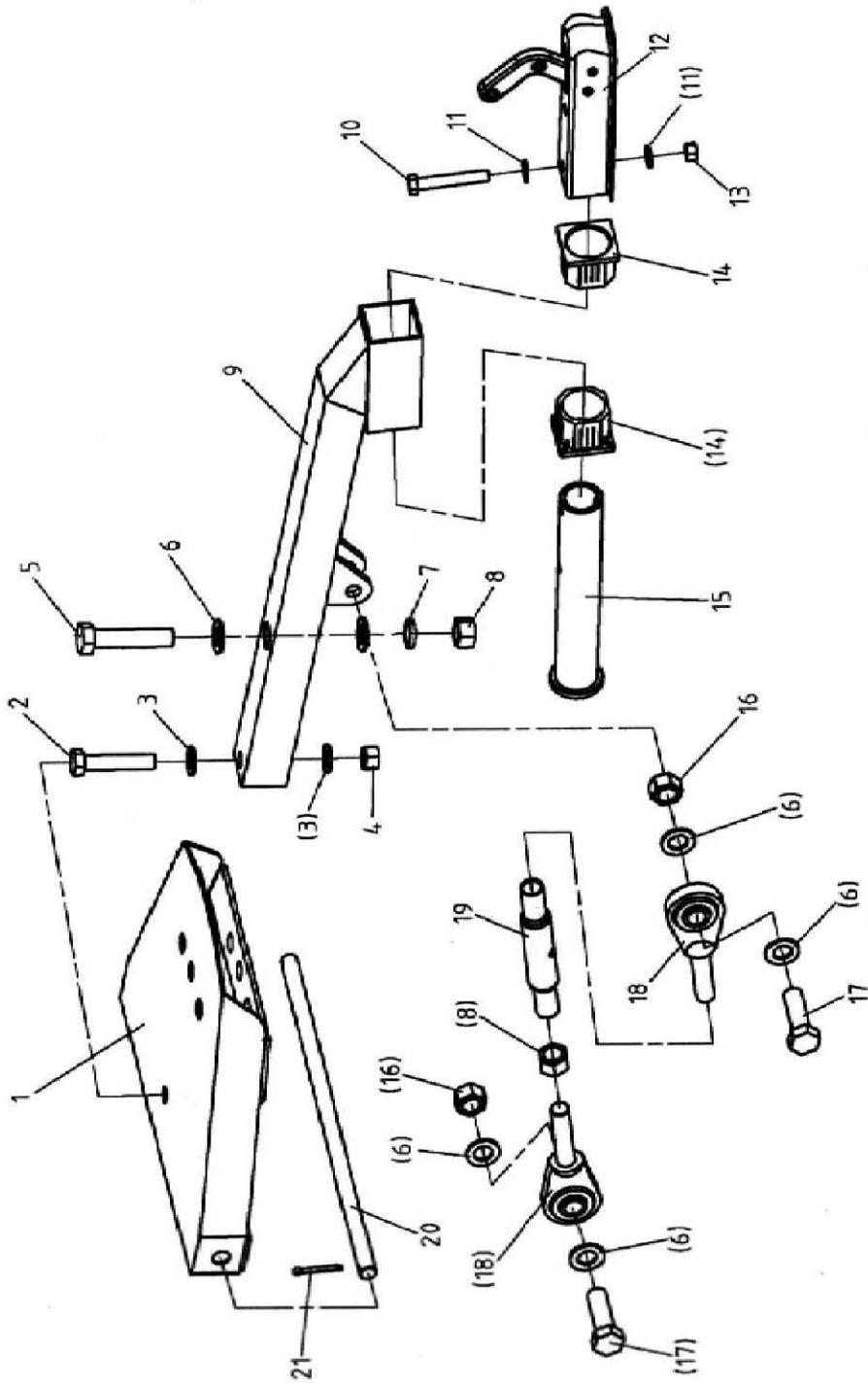

Traction Assembly

NO.	Part NO.	Name & Specifications	Quantity	Remark
1	ATV120.013	Soleplate weldment	1	
2	GB5782-86	Blot M16x80	1	
3	GB97.1-85	Plain washer 16	3	
4	GB184-86	Locking nut M16	1	
5	GB5782-86	Blot M20x90	1	
6	GB97.1-85	Plain washer 20	5	
7	GB93-87	Spring washer 20	1	
8	GB6170-86	Nut M20	2	
9	ATV120.00.015	Bracket for traction	1	
10	GB5782-86	Blot M12x80	2	
11	GB97.1-85	Plain washer 12	4	
12	GM8835	Hook for traction	1	
13	GB6184-86	Locking nut M12	2	
14	7CB-0.25-131	Axle sleeve	2	
15	7CB-0.25-129	Shaft tube for traction	1	
16	GB6184-86	Locking nut M20	2	
17	GB5783-86	Blot M20X65	2	
18	MFP120.00.014-1	Lifting handle	1	
19	MFP120.00.014-2	Lifting coil	1	
20	MFP120.00.102	Pin shaft	1	
21	GB91-86	Split pin 5x32	2	